

ALLROUNDER 375 V

Vertical free-space system

Clamping force: 500 kN

Injection unit (acc. to EUROMAP): 100, 170, 290

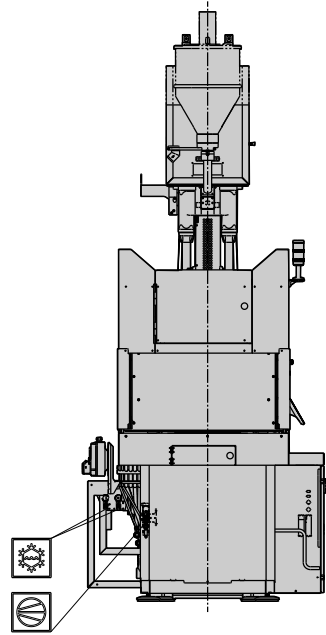
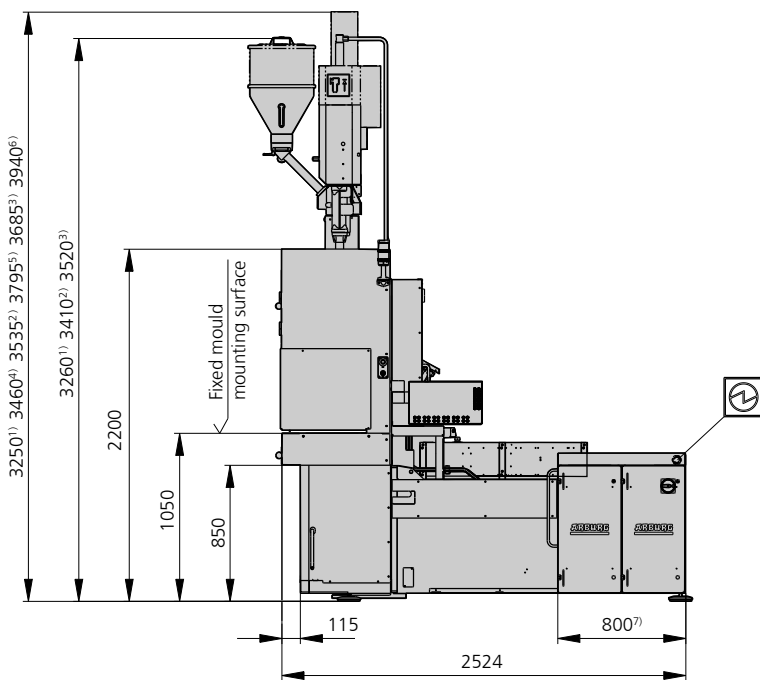

ARBURG

INSTALLATION DIMENSIONS - STANDARD | 375 V in technology stage T1

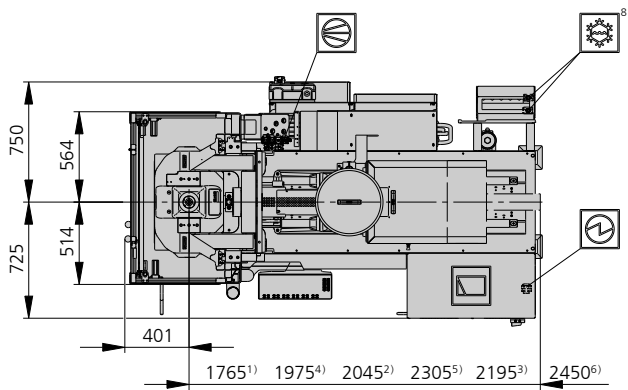
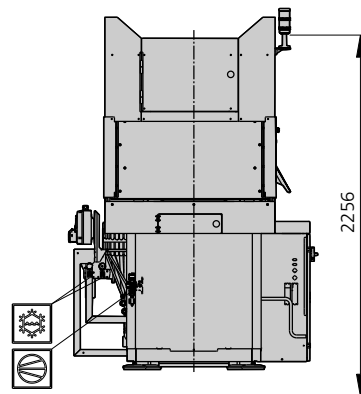
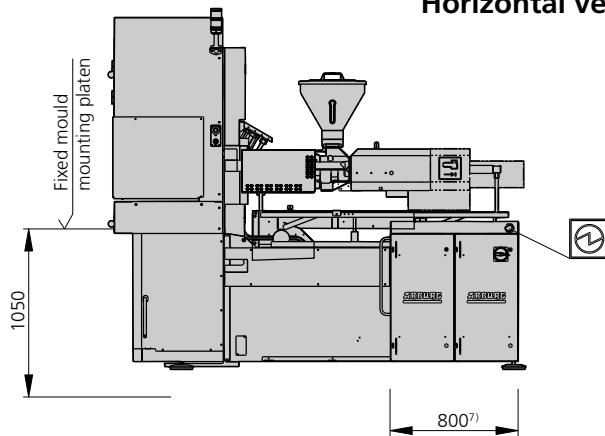

Horizontal version



-  Electrical connection
-  Cooling water connection
-  Pneumatic connection

- 1) Injection unit 100
- 2) Injection unit 170
- 3) Injection unit 290
- 4) Injection unit 100 AED
- 5) Injection unit 170 AED
- 6) Injection unit 290 AED
- 7) Additional control cabinet dependent on version
- 8) Position of cooling water connection can vary due to optional equipment

TECHNICAL DATA | 375 V in technology stage T1

Clamping unit		375 V		
with clamping force	max. kN	500		
Version		Standard	Rotary table	Shuttle table
Opening force stroke	max. kN mm	30 250	30 250	30 250
Mould height, fixed variable	min.-max. mm	--- 200-300	--- 170-270	--- 172-272
Platen daylight fixed variable	max. mm	--- 450-550	--- 420-520	--- 422-522
Table diameter	mm	---	900	---
Shuttle table stroke	mm	---	---	650
Angle of rotation, left/right		---	180°	---
Rotation time for 180°	min. s	---	2,3	1,9
Weight on rotary/shuttle table	max. kg	---	240	240
Weight of movable mould half	max. kg	230	230	230
Ejector force stroke	max. kN mm	30 70	30 70	30 70
Dry cycle time EUROMAP ²	min. s - mm	3 - 240	3 - 240	3 - 240

Injection unit		100			170			290		
with screw diameter	mm	20	25	30	25	30	35	30	35	40
Effective screw length	L/D	25	20	16,7	24	20	17	23,3	20	17,5
Screw stroke	max. mm	100			120			150		
Calculated stroke volume	max. cm ³	31	49	71	59	85	115	106	144	188
Shot weight	max. g PS	29	45	65	54	77	105	97	132	172
Material throughput	max. kg/h PS	5,5	8	9,5	10	13,5	16	17	20,5	24,5
	max. kg/h PA6.6	2,8	4	4,9	5	7	8	8,5	10,5	12,5
Injection pressure	max. bar	2500	2000	1390	2500	2000	1470	2500	2000	1530
Holding pressure	max. bar	2500	2000	1390	2500	2000	1470	2500	2000	1530
Injection flow ²	max. cm ³ /s	64	100	146	66	96	132	72	100	130
Screw circumferential speed ²	max. m/min	28	35	42	35	42	49	33	39	44
Screw torque	max. Nm	120	150	180	210	250	290	320	380	430
Nozzle contact force retraction stroke	max. kN mm	50 180			50 210			60 240		
Heating capacity zones	kW	6,7 5			9 5			7,7 5		
Feed hopper	l	25			25			25		

Drive and connection		Standard			Drehtisch			Schiebetisch		
with injection unit		100	170	290	100	170	290	100	170	290
Net weight of machine	kg	3150	3250	3300	3700	3800	3850	3700	3800	3850
Sound press. level Insecurity ⁴	dB(A)	65 3			65 3			65 3		
Oil filling	l	160			160			160		
Drive power ²	max. kW	11			11			11		
Electrical connection ³	kW	18	22	20	18	22	20	18	22	20
	Total	A			63			63		
	Machine	A			---			---		
	Heating	A			---			---		
Cooling water connection	max. °C	25			25			25		
	min. Δp bar	1,5 DN 25			1,5 DN 25			1,5 DN 25		

Machine type

with EUROMAP size designation ¹

375 V 500-100 | 170 | 290

Upon request: other machine types and mould installation heights, screws, drive powers, etc.

All specifications relate to the basic machine version. Deviations are possible, depending on variants, process settings and material type. Depending on the drive, certain combinations, e.g. max. injection pressure and max. injection flow may be mutually exclusive.

- 1) Clamping force (kN) - large injection unit = max. stroke volume (cm³) x max. injection pressure (kbar)
 - 2) Specifications depend on the drive variant / drive configuration.
 - 3) Specifications relate to 400 V/50 Hz.
 - 4) Emission sound pressure level at the workplace. Detailed information in the operating instructions.
- [] Specifications apply to alternative equipment.

MOULD INSTALLATION DIMENSIONS - STANDARD | 375 V in technology stage T1

Ejector bolt | X

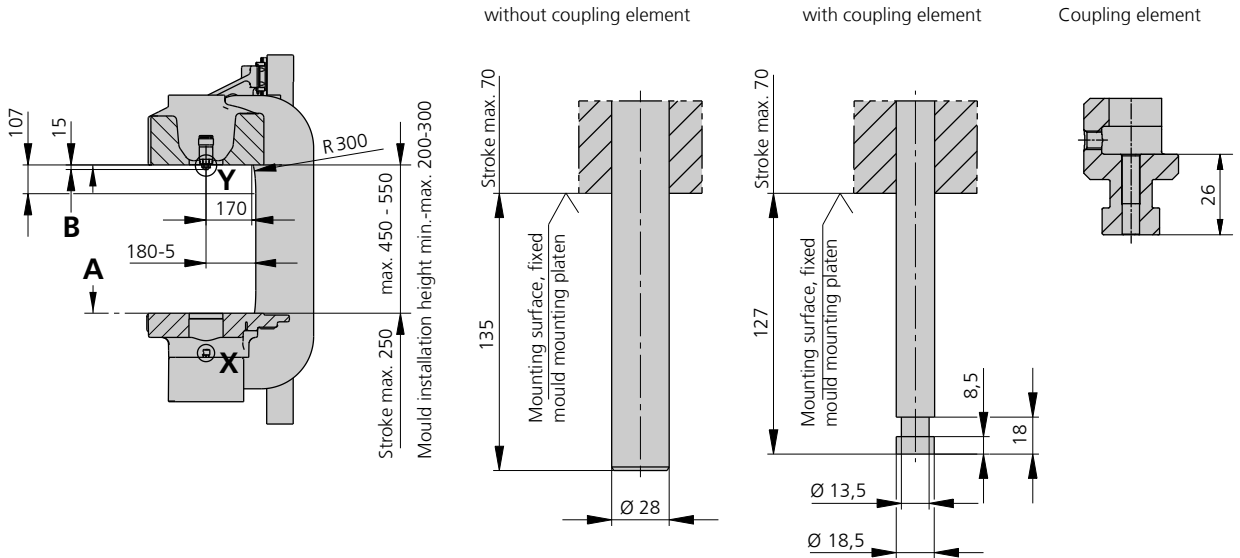

Cut-out in mould (if required) | Y

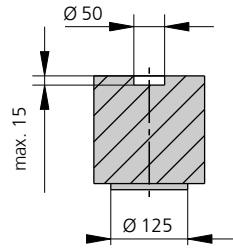

Horizontal version

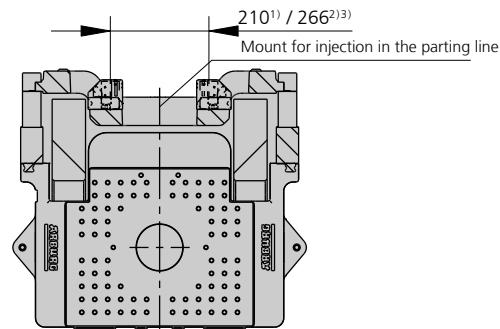
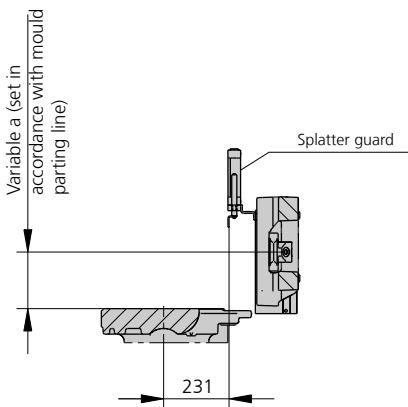

Cut-out in mould (if required)

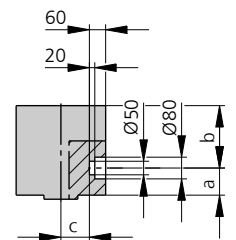

	Injection position	... with hydraulic nozzle		
		Injection unit 100	Injection unit 170	Injection unit 290
a min.	100	100	100	100
a max.	200	200	200	200
b min.	100	100	100	100
c min.	97	77	83	76

1) Injection unit 100
2) Injection unit 170
3) Injection unit 290

MOULD INSTALLATION DIMENSIONS - STANDARD | 375 V in technology stage T1

Fixed mould mounting platen | A

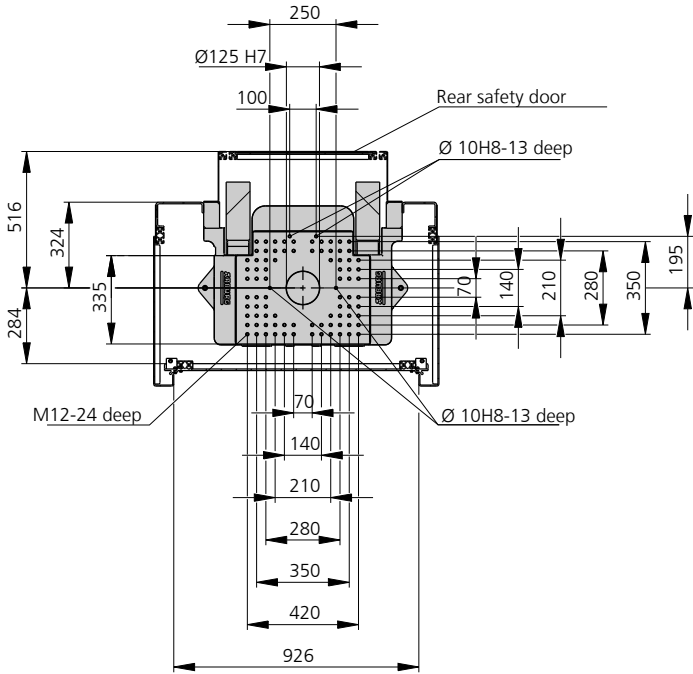

Moving mould mounting platen | B

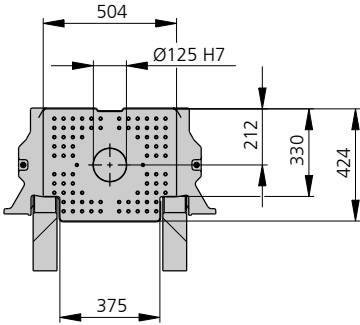

ROTARY TABLE INSTALLATION DIMENSIONS | 375 V in technology stage T1

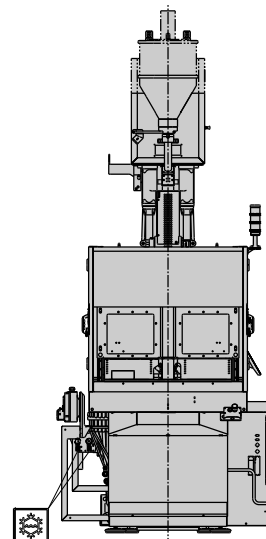
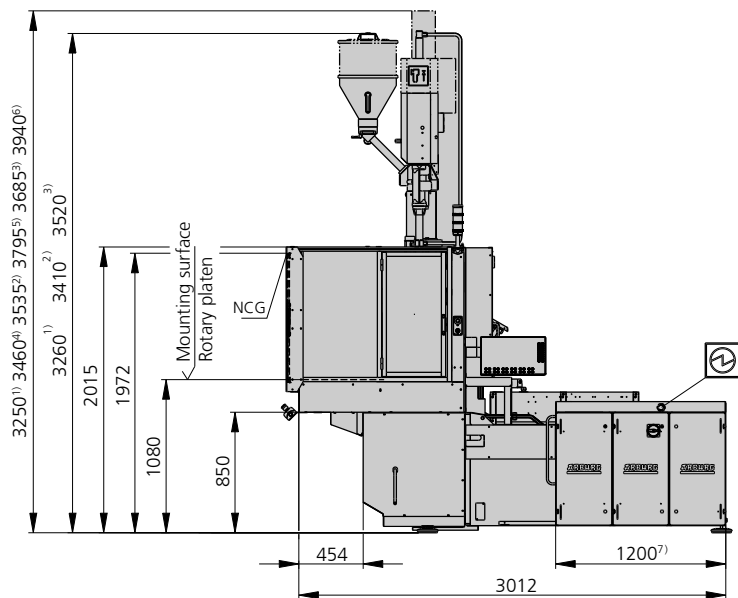

Horizontal version

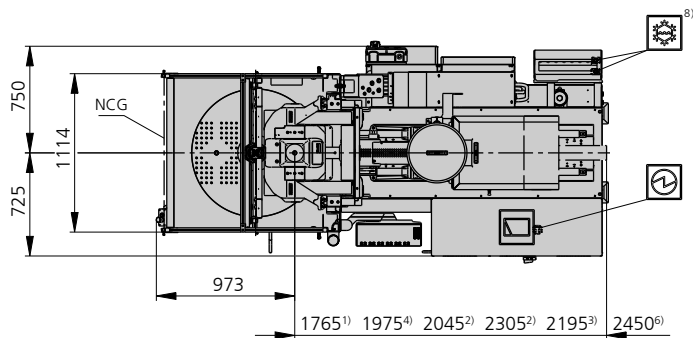
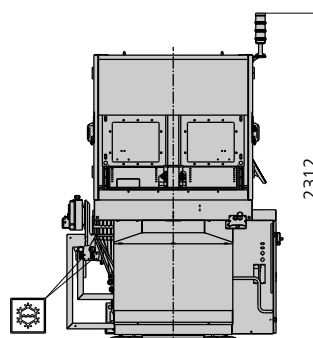
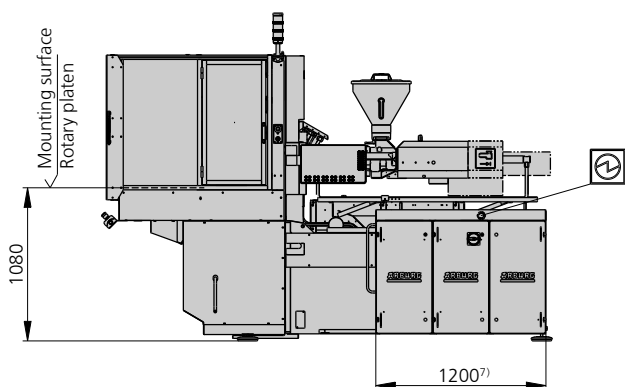

 Electrical connection

 Cooling water connection

- 1) Injection unit 100
- 2) Injection unit 170
- 3) Injection unit 290
- 4) Injection unit 100 AED
- 5) Injection unit 170 AED
- 6) Injection unit 290 AED
- 7) Additional control cabinet dependent on version
- 8) Position of cooling water connection can vary due to optional equipment

NCG - Non-contacting guard (photoelectric safety barrier)

MOULD INSTALLATION DIMENSIONS FOR ROTARY TABLE | 375 V

in technology stage T1

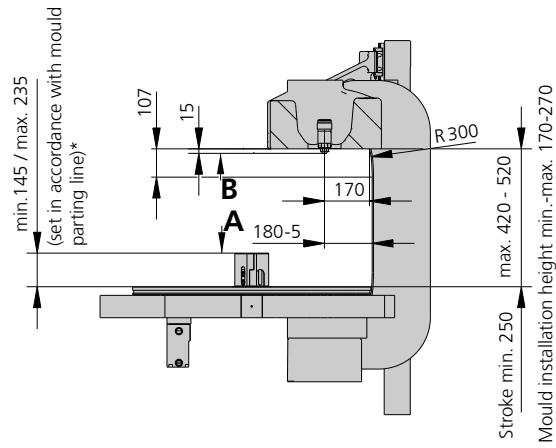

Ejector bolt (for gentle ejection)

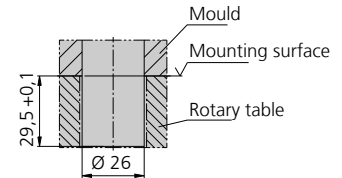

*(max. height: observe mold parting line with ejector stroke; with vertical injection unit observe height of sprue)

Fixed mould mounting platen, rotary table | A

Usable mounting surface

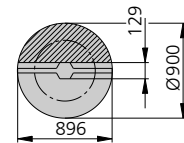
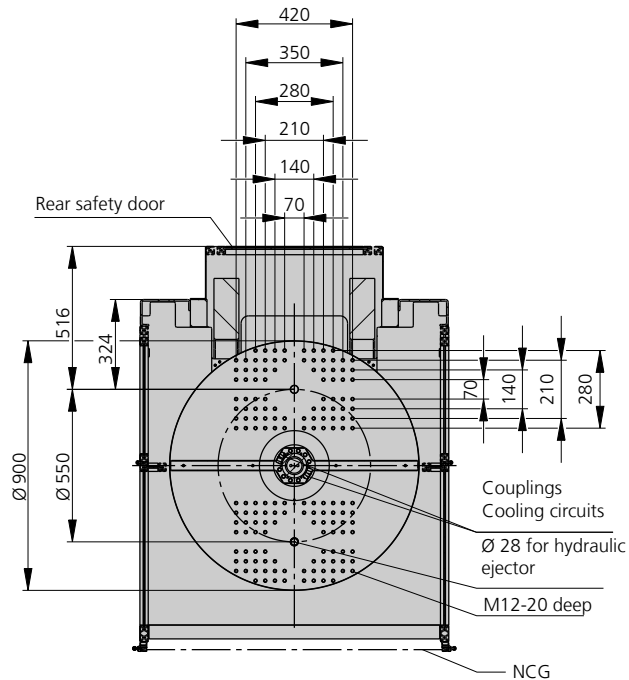

Moving mould mounting platen | B

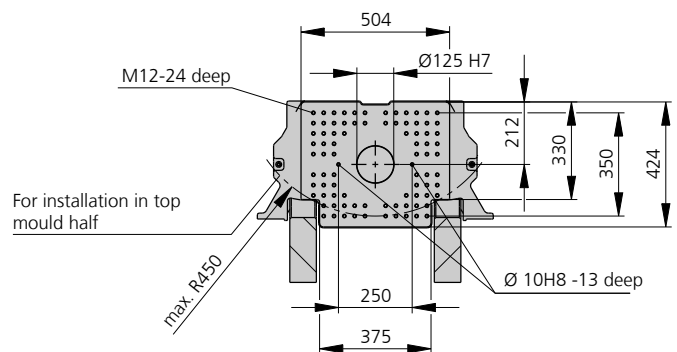

NCG - Non-contacting guard (photoelectric safety barrier)

MOULD INSTALLATION DIMENSIONS FOR ROTARY TABLE | 375 V

in technology stage T1

Horizontal version

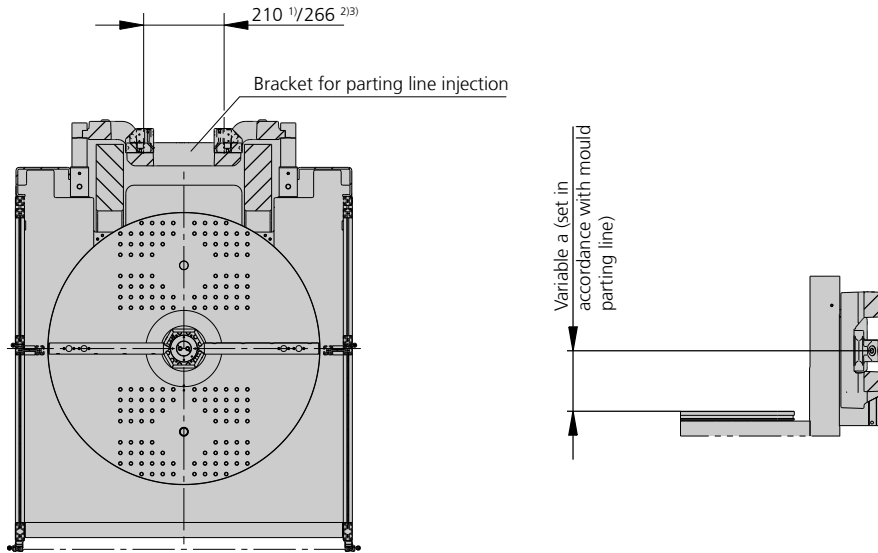

Cut-out in mould (if required)

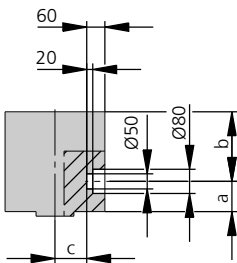

	Injection position			... with hydraulic nozzle		
	Injection unit					
	100	70	290	100	170	290
a min.	100			100		
a max.	200			200		
b min.	100			100		
c min.	97			77	83	76

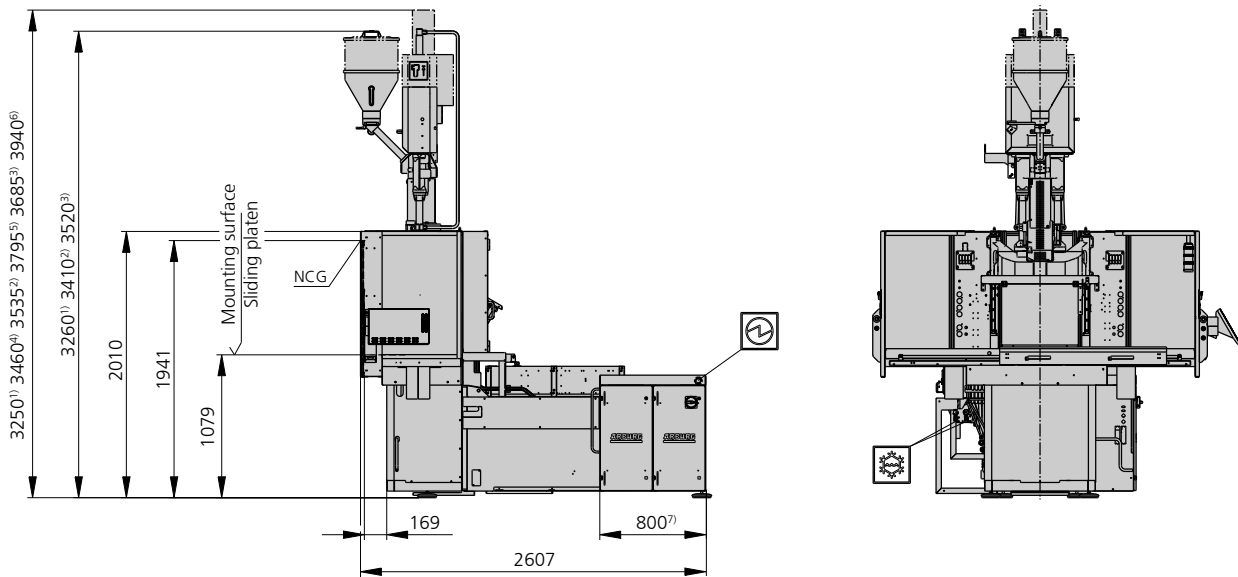

1) Injection unit 100
2) Injection unit 170
3) Injection unit 290

INSTALLATION DIMENSIONS - SLIDING TABLE | 375 V in technology stage T1

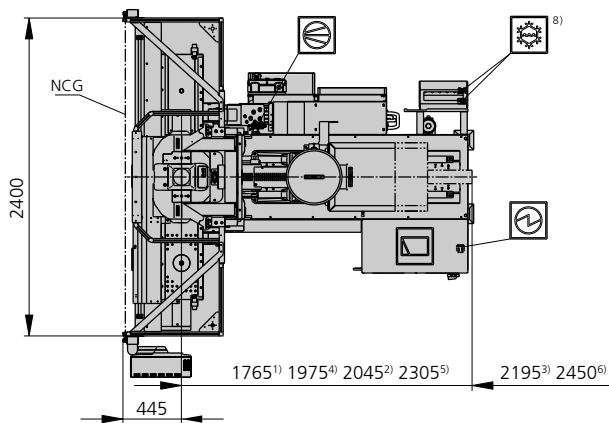
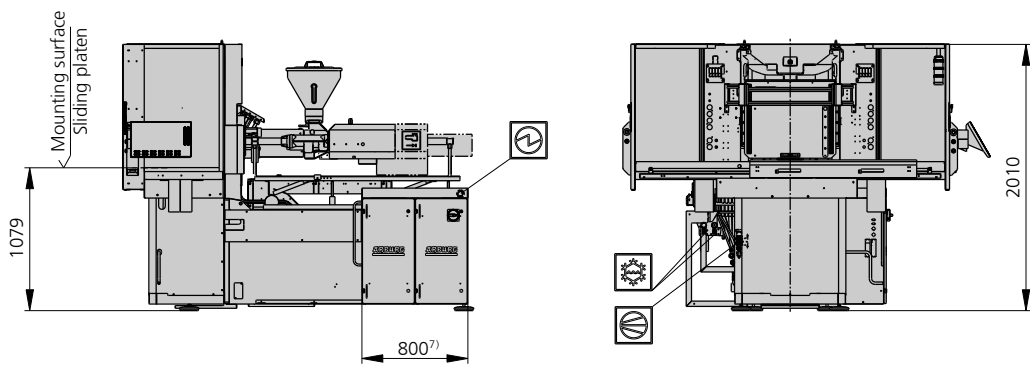

Horizontal version



-  Electrical connection
-  Cooling water connection
-  Pneumatic connection

- 1) Injection unit 100
- 2) Injection unit 170
- 3) Injection unit 290
- 4) Injection unit 100 AED
- 5) Injection unit 170 AED
- 6) Injection unit 290 AED
- 7) Additional control cabinet dependent on version
- 8) Position of cooling water connection can vary due to optional equipment

NCG - Non-contacting guard (photoelectric safety barrier)

MOULD INSTALLATION DIMENSIONS - SLIDING TABLE | 375 V

in technology stage T1

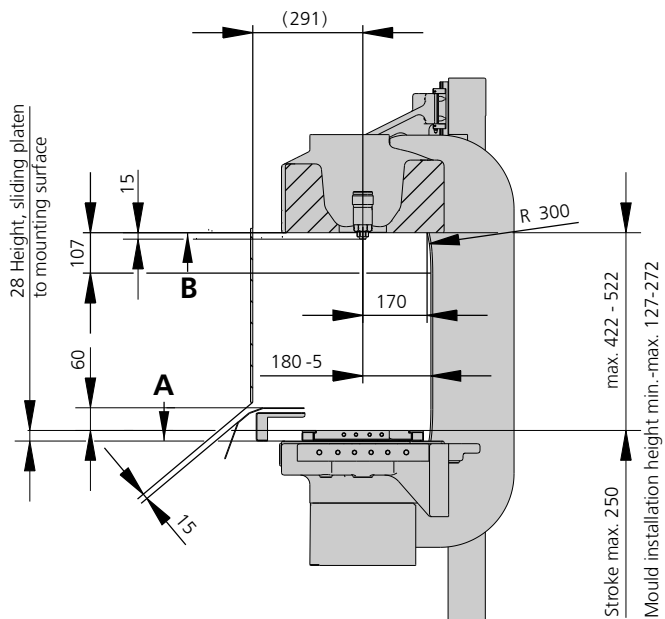

Sliding table | A

Ejector bolt (for gentle ejection)

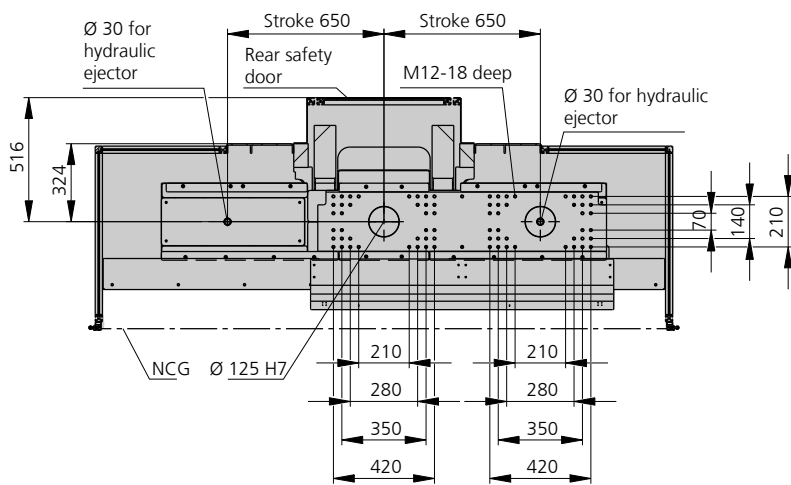
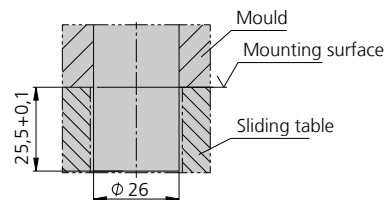

Moving mould mounting platen | B

Usable mounting surface

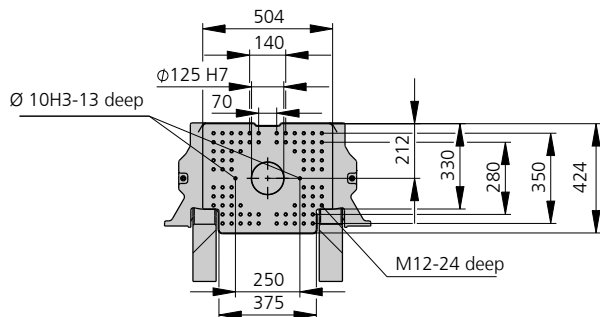
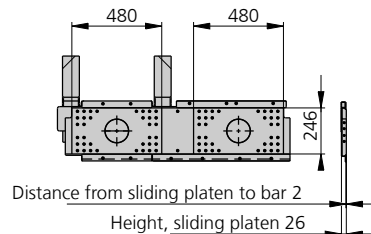

MOULD INSTALLATION DIMENSIONS - SLIDING TABLE | 375 V

in technology stage T1

Horizontal version

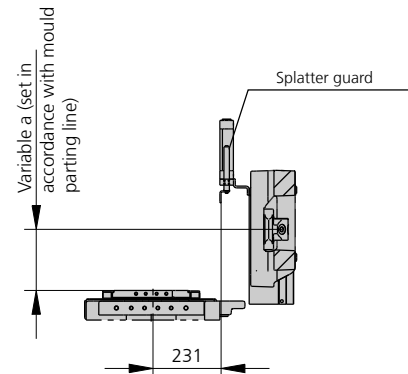
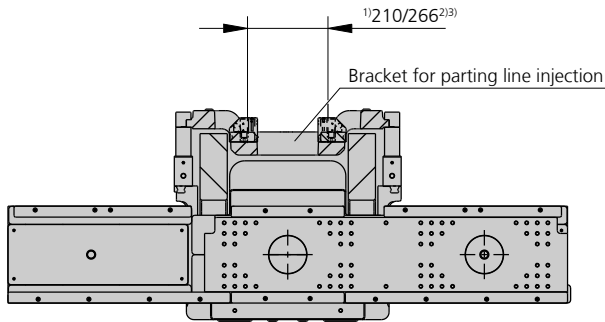

Cut-out in mould (if required)

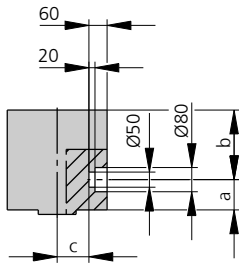

	Injection position			... with hydraulic nozzle		
	100	70	290	Injection unit		
	100	70	290	100	170	290
a min.	100			100		
a max.	200			200		
b min.	100			100		
c min.	97			77	83	76

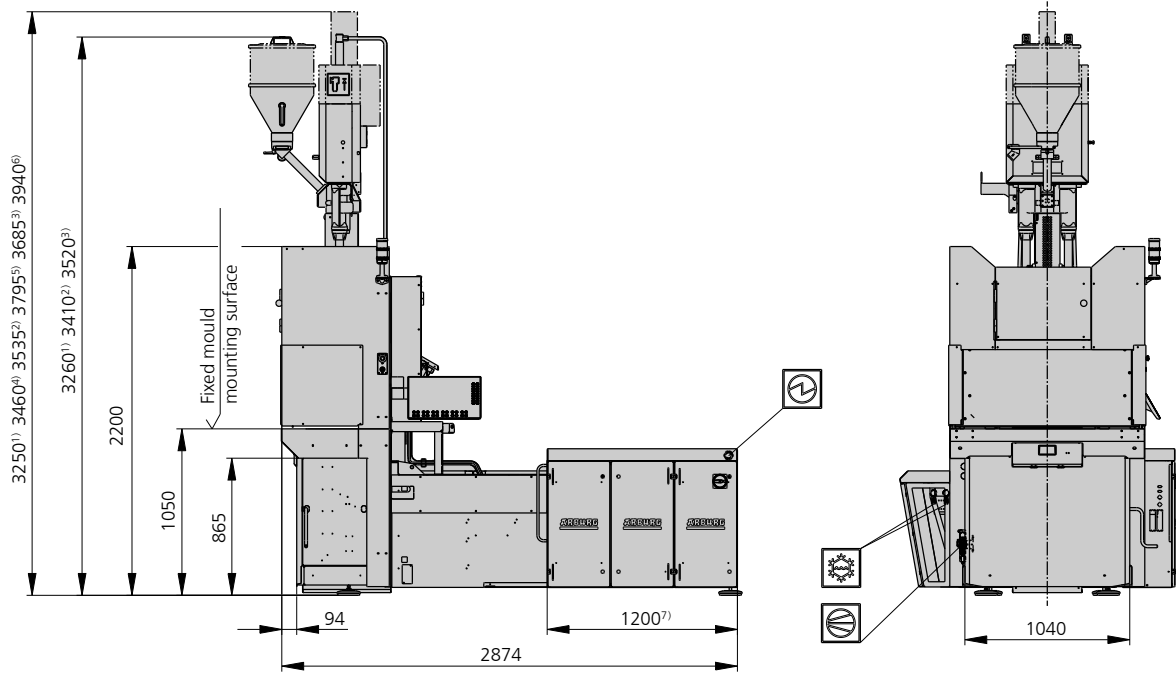

1) Injection unit 100
 2) Injection unit 170
 3) Injection unit 290

INSTALLATION DIMENSIONS - STANDARD | 375 V in technology stage T2

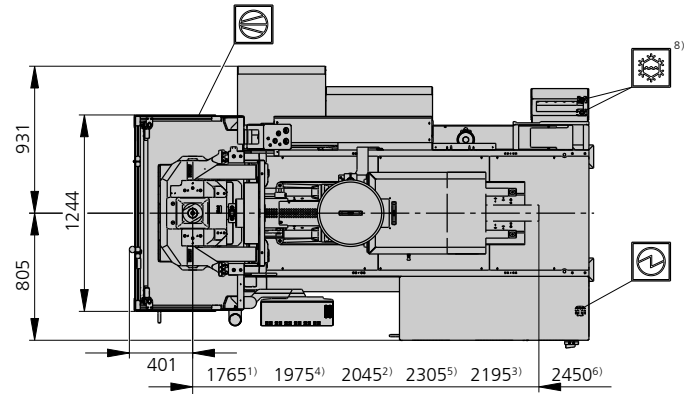
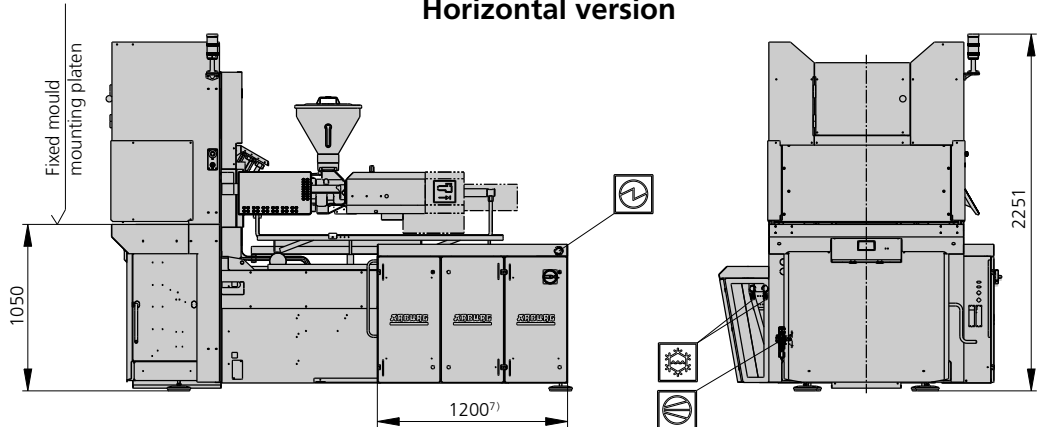

Horizontal version



-  Electrical connection
-  Cooling water connection
-  Pneumatic connection

- 1) Injection unit 100
- 2) Injection unit 170
- 3) Injection unit 290
- 4) Injection unit 100 AED
- 5) Injection unit 170 AED
- 6) Injection unit 290 AED
- 7) Additional control cabinet dependent on version
- 8) Position of cooling water connection can vary due to optional equipment

TECHNICAL DATA | 375 V in technology stage T2

Clamping unit		375 V		
with clamping force	max. kN	500		
Version		Standard	Rotary table	Shuttle table
Opening force stroke	max. kN mm	30 250	30 250	30 250
Mould height, fixed variable	min.-max. mm	--- 200-300	--- 170-270	--- 172-272
Platen daylight fixed variable	max. mm	--- 450-550	--- 420-520	--- 422-522
Table diameter	mm	---	900	---
Shuttle table stroke	mm	---	---	650
Angle of rotation, left/right		---	180°	---
Rotation time for 180°	min. s	---	2,3	1,9
Weight on rotary/shuttle table	max. kg	---	240	240
Weight of movable mould half	max. kg	230	230	230
Ejector force stroke	max. kN mm	30 70	30 70	30 70
Dry cycle time EUROMAP ²	min. s - mm	2 - 240	2 - 240	2 - 240

Injection unit		100			170			290		
with screw diameter	mm	20	25	30	25	30	35	30	35	40
Effective screw length	L/D	25	20	16,7	24	20	17	23,3	20	17,5
Screw stroke	max. mm	100			120			150		
Calculated stroke volume	max. cm ³	31	49	71	59	85	115	106	144	188
Shot weight	max. g PS	29	45	65	54	77	105	97	132	172
Material throughput	max. kg/h PS	5,5	8	9,5	10	13,5	16	17	20,5	24,5
	max. kg/h PA6.6	2,8	4	4,9	5	7	8	8,5	10,5	12,5
Injection pressure	max. bar	2500	2000	1390	2500	2000	1470	2500	2000	1530
Holding pressure	max. bar	2500	2000	1390	2500	2000	1470	2500	2000	1530
Injection flow ²	max. cm ³ /s	90	142	204	94	136	186	102	140	182
Screw circumferential speed ²	max. m/min	28	35	42	35	42	49	33	39	44
Screw torque	max. Nm	120	150	180	210	250	290	320	380	430
Nozzle contact force retraction stroke	max. kN mm	50 180			50 210			60 240		
Heating capacity zones	kW	6,7 5			9 5			7,7 5		
Feed hopper	l	25			25			25		

Drive and connection		Standard			Rotary table			Shuttle table			
with injection unit		100	170	290	100	170	290	100	170	290	
Net weight of machine	kg	3400	3500	3550	4100	4200	4250	4100	4200	4250	
Sound press. level Insecurity ⁴	dB(A)	65 3			65 3			65 3			
Oil filling	l	190			190			190			
Drive power ²	max. kW	15			15			15			
Electrical connection ³	kW	24	26	25	24	27	25	24	26	25	
	Total	A	50	50	50	63	50	50	50	50	
	Machine	A	---			---			---		
	Heating	A	---			---			---		
Cooling water connection	max. °C	25			25			25			
	min. Δp bar	1,5 DN 25			1,5 DN 25			1,5 DN 25			

Machine type

with EUROMAP size designation ¹

375 V 500-100 | 170 | 290

Upon request: other machine types and mould installation heights, screws, drive powers, etc.

All specifications relate to the basic machine version. Deviations are possible, depending on variants, process settings and material type. Depending on the drive, certain combinations, e.g. max. injection pressure and max. injection flow may be mutually exclusive.

1) Clamping force (kN) - large injection unit = max. stroke volume (cm³) x max. injection pressure (kbar)

2) Specifications depend on the drive variant / drive configuration.

3) Specifications relate to 400 V/50 Hz.

4) Emission sound pressure level at the workplace. Detailed information in the operating instructions.

[] Specifications apply to alternative equipment.

MOULD INSTALLATION DIMENSIONS - STANDARD | 375 V in technology stage T2

Ejector bolt | X

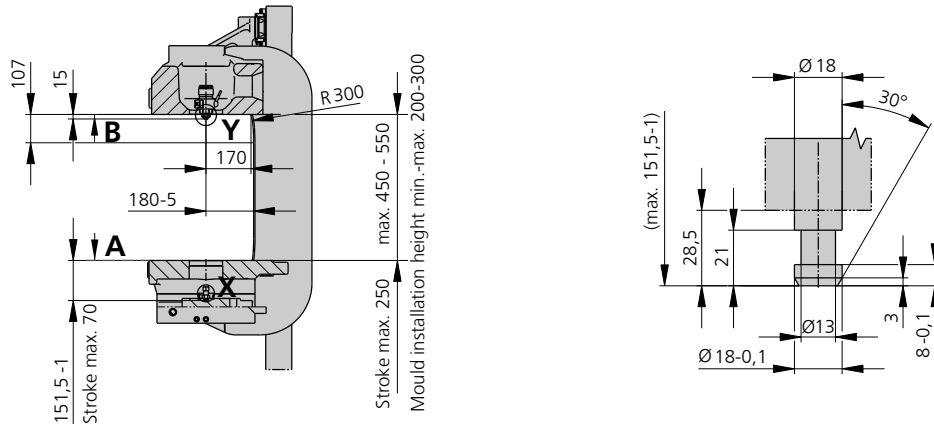

Cut-out in mould (if required) | Y

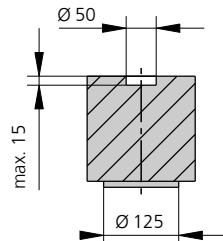

Horizontal version

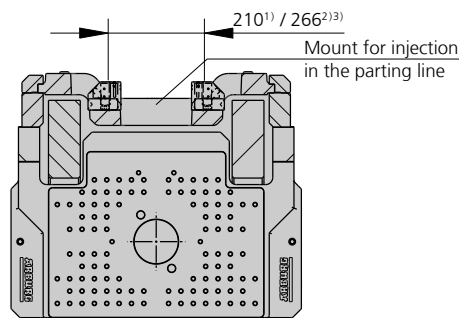
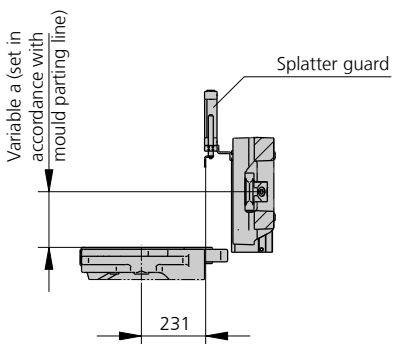

Cut-out in mould (if required)

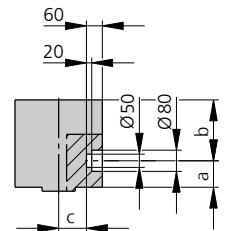

- 1) Injection unit 100
- 2) Injection unit 170
- 3) Injection unit 290

	Injection position			... with hydraulic nozzle		
	Injection unit					
	100	170	290	100	170	290
a min.	100			100		
a max.	200			200		
b min.	100			100		
c min.	97			77	83	76

MOULD INSTALLATION DIMENSIONS - STANDARD | 375 V in technology stage T2

Fixed mould mounting platen | A

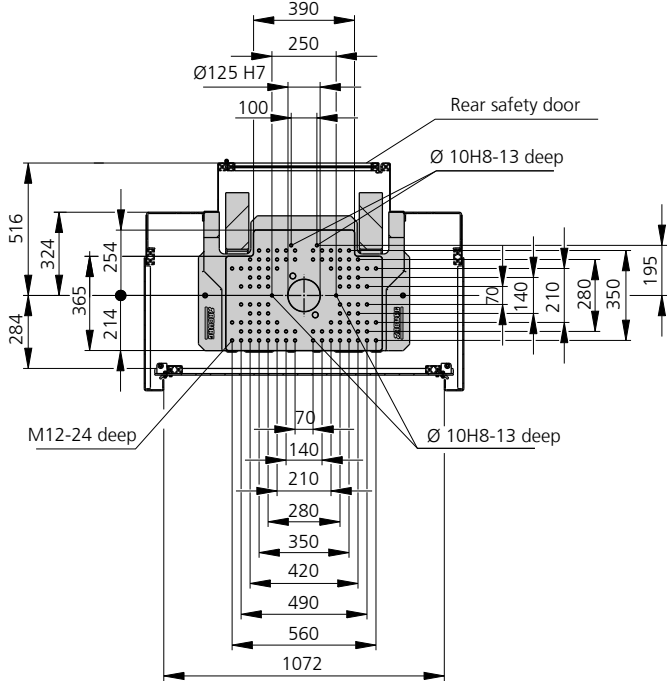

Moving mould mounting platen | B

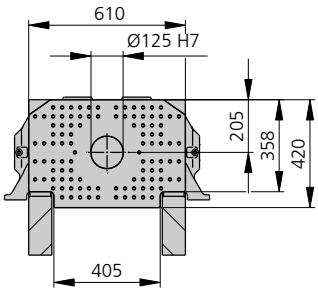

INSTALLATION DIMENSIONS - ROTARY TABLE | 375 V in technology stage T2

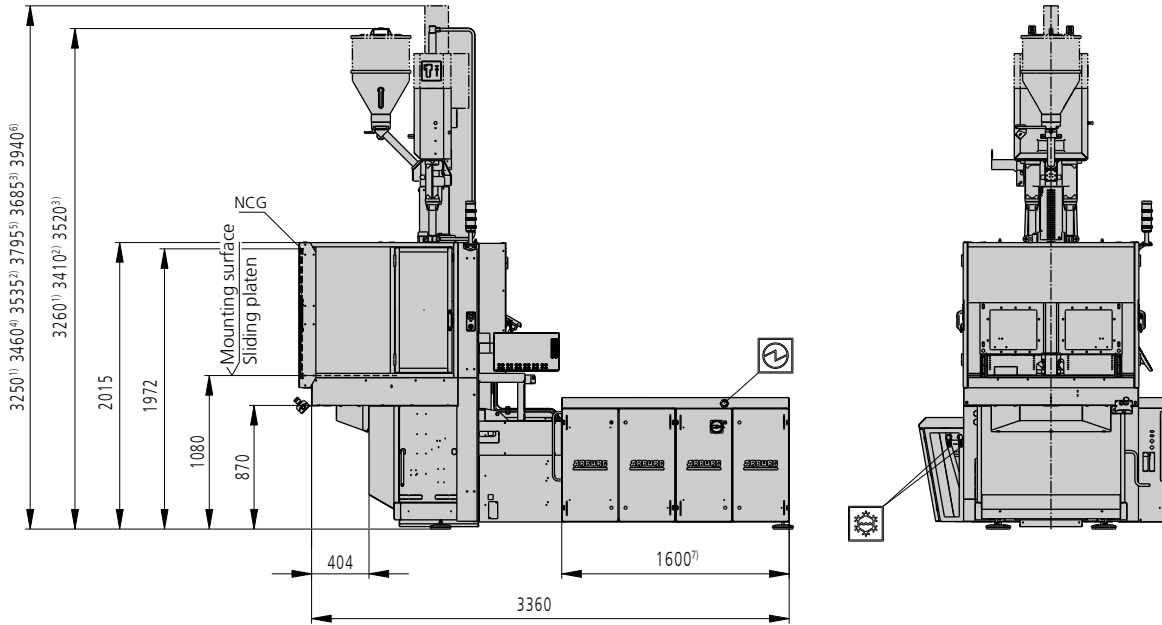

Horizontal version

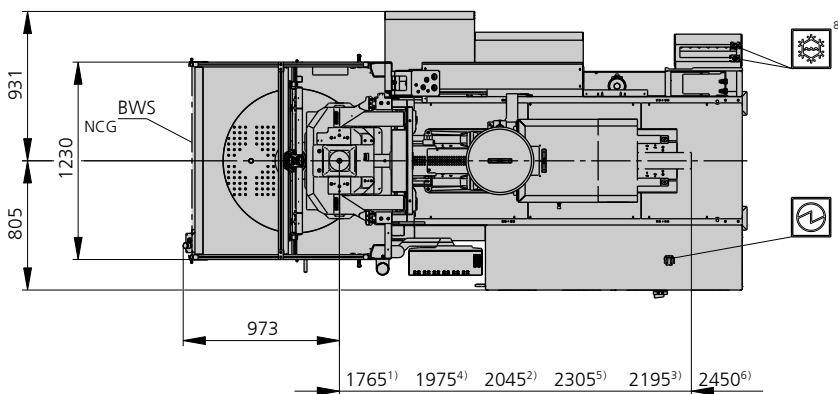
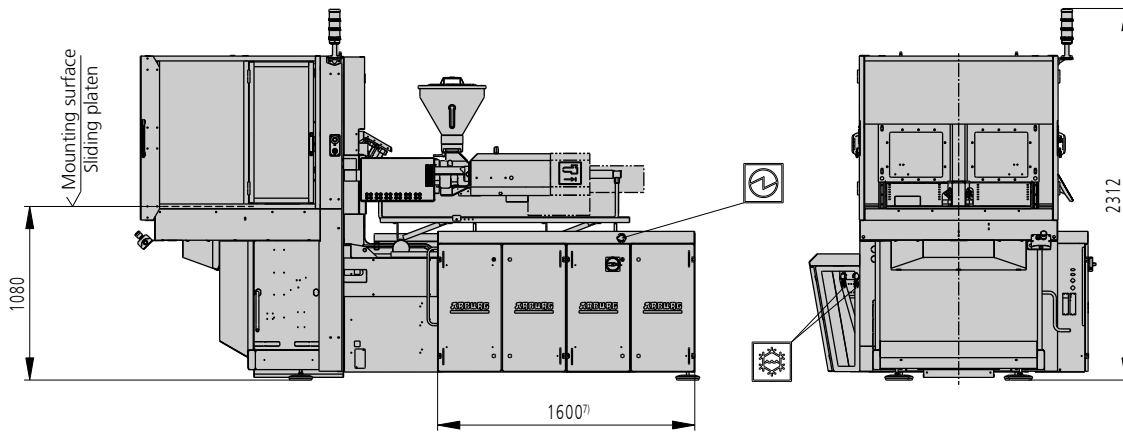

⚡ Electrical connection

💧 Cooling water connection

- 1) Injection unit 100
- 2) Injection unit 170
- 3) Injection unit 290
- 4) Injection unit 100 AED
- 5) Injection unit 170 AED
- 6) Injection unit 290 AED
- 7) Additional control cabinet dependent on version
- 8) Position of cooling water connection can vary due to optional equipment

NCG - Non-contacting guard (photoelectric safety barrier)

MOULD INSTALLATION DIMENSIONS FOR ROTARY TABLE | 375 V

in technology stage T2

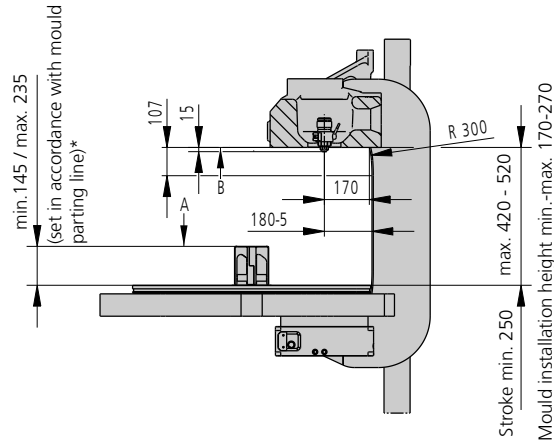

*(max. height: observe mold parting line with ejector troke; with vertical injection unit observe height of sprue)

Ejector bolt (for gentle ejection)

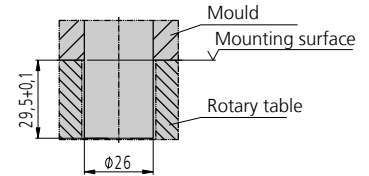

Fixed mould mounting platen, rotary table | A

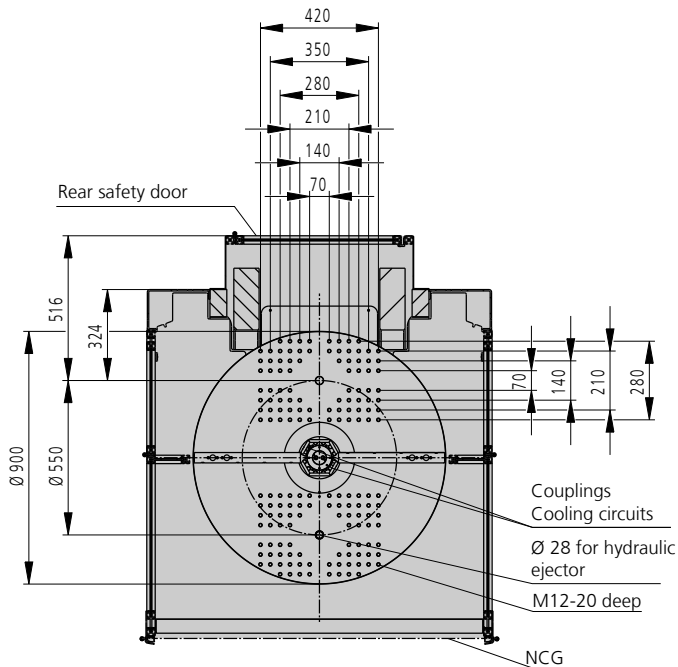

Usable mounting surface

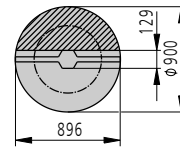

Moving mould mounting platen | B

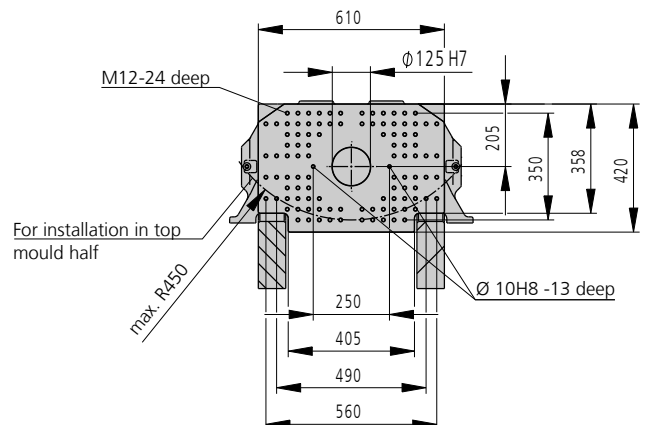

NCG - Non-contacting guard (photoelectric safety barrier)

MOULD INSTALLATION DIMENSIONS FOR ROTARY TABLE | 375 V

in technology stage T2

Horizontal version

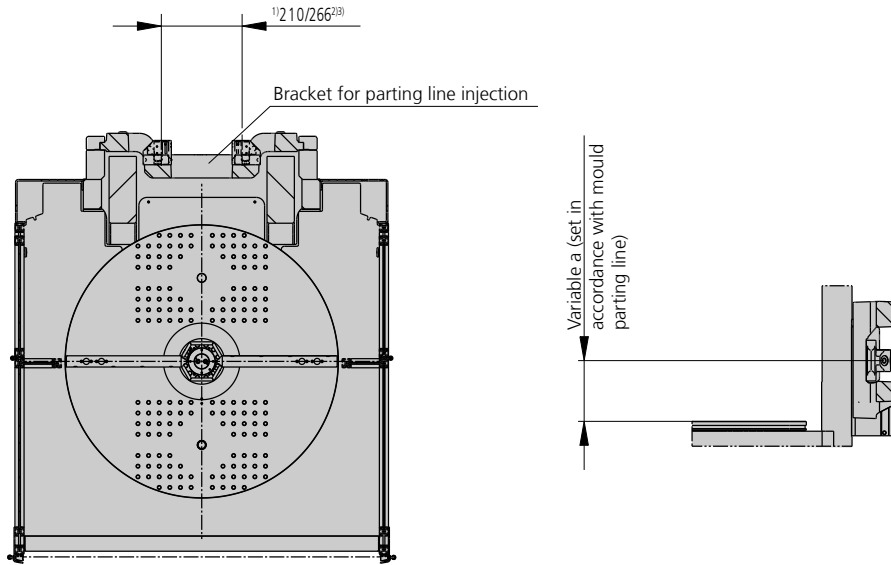

Cut-out in mould (if required)

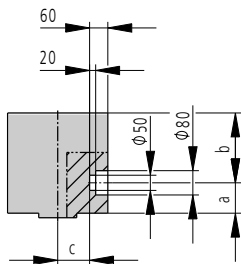

	Injection position			... with hydraulic nozzle		
	Injection unit					
	100	70	290	100	170	290
a min.	100			100		
a max.	200			200		
b min.	100			100		
c min.	97			77	83	76

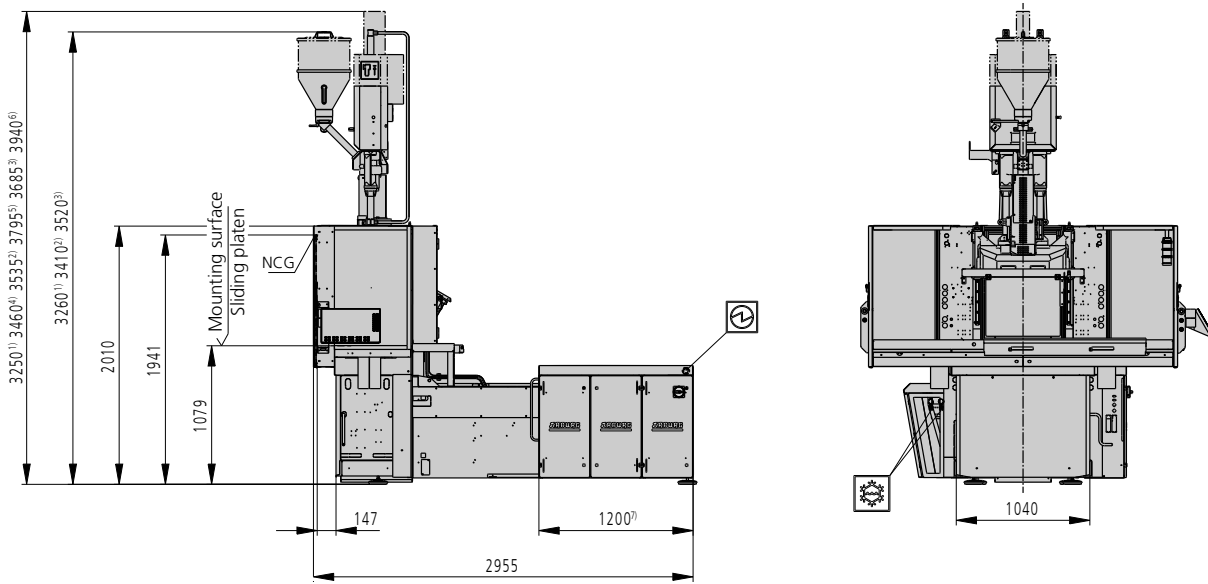

- 1) Injection unit 100
- 2) Injection unit 170
- 3) Injection unit 290

INSTALLATION DIMENSIONS - SLIDING TABLE | 375 V in technology stage T1

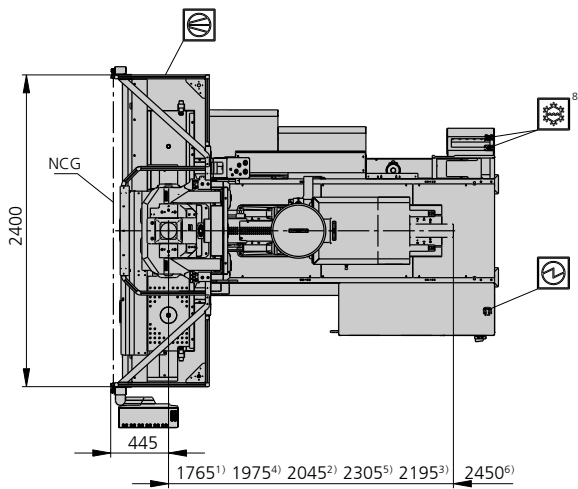
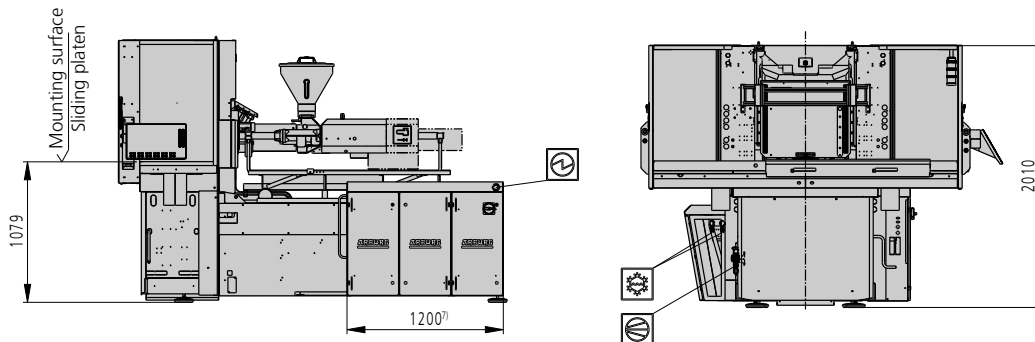

Horizontal version



-  Electrical connection
-  Cooling water connection
-  Pneumatic connection

- 1) Injection unit 100
- 2) Injection unit 170
- 3) Injection unit 290
- 4) Injection unit 100 AED
- 5) Injection unit 170 AED
- 6) Injection unit 290 AED
- 7) Additional control cabinet dependent on version
- 8) Position of cooling water connection can vary due to optional equipment

NCG - Non-contacting guard (photoelectric safety barrier)

MOULD INSTALLATION DIMENSIONS - SLIDING TABLE | 375 V

in technology stage T2

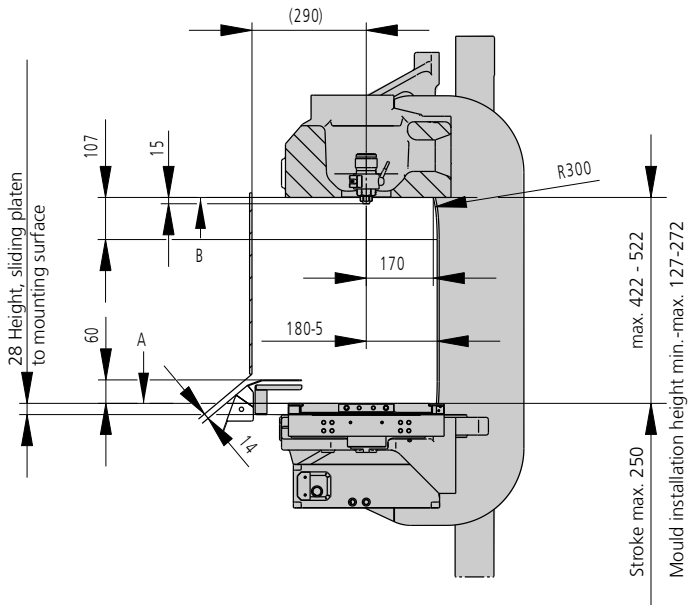

Ejector bolt (for gentle ejection)

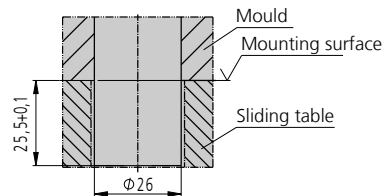

Sliding table | A

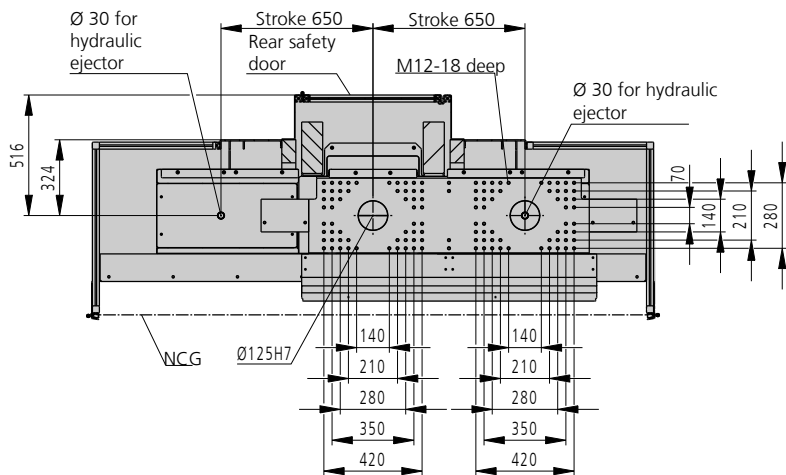

Usable mounting surface

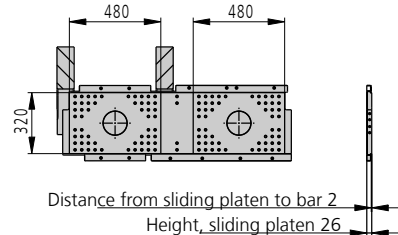

Moving mould mounting platen | B

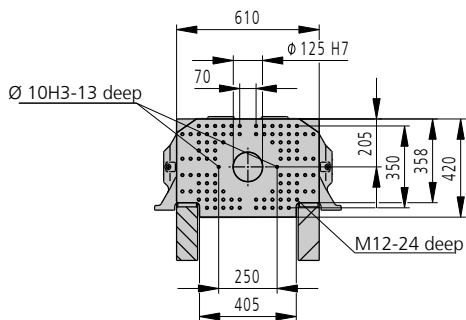

MOULD INSTALLATION DIMENSIONS - SLIDING TABLE | 375 V

in technology stage T2

Horizontal version

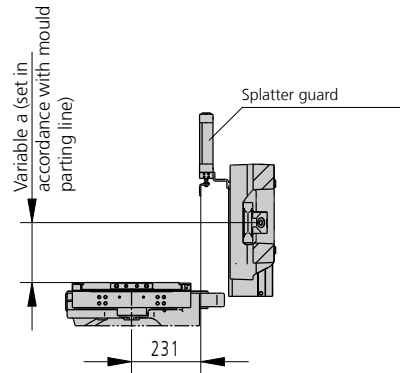
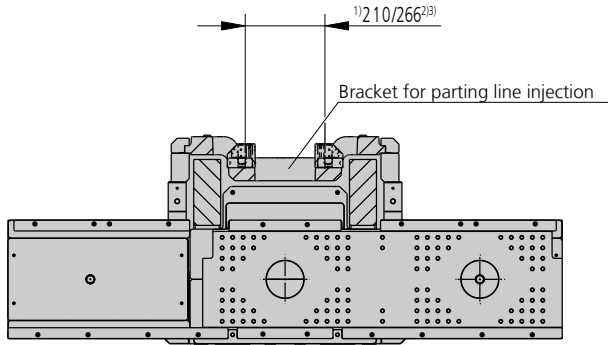

Cut-out in mould (if required)

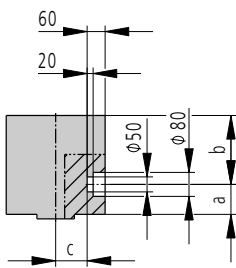

	Injection position			... with hydraulic nozzle		
	Injection unit					
	100	70	290	100	170	290
a min.	100			100		
a max.	200			200		
b min.	100			100		
c min.	97			77	83	76

1) Injection unit 100
 2) Injection unit 170
 3) Injection unit 290

SHOT WEIGHTS | 375 V

Theoretical shot weights for the most important injection moulding materials

Injection units according to EUROMAP		100			170			290		
Screw diameter	mm	20	25	30	25	30	35	30	35	40
Polystyrene	max. g PS	29	45	65	54	77	105	97	132	172
Styrene heteropolymerizates	max. g SB	28	44	63	53	76	103	95	129	168
	max. g SAN, ABS ¹⁾	27	43	62	52	74	101	93	126	165
Cellulose acetate	max. g CA ¹⁾	32	50	73	61	87	119	109	148	194
Celluloseacetobutyrate	max. g CAB ¹⁾	30	47	68	56	81	110	101	138	180
Polymethyl methacrylate	max. g PMMA	30	46	67	56	80	109	100	136	178
Polyphenylene ether, mod.	max. g PPE	27	42	60	50	72	98	90	122	160
Polycarbonate	max. g PC	30	47	68	57	81	111	102	139	181
Polysulphone	max. g PSU	31	49	70	58	84	115	105	143	187
Polyamides	max. g PA 6.6 PA 6 ¹⁾	28	44	64	53	77	104	96	131	171
	max. g PA 6.10 PA 11 ¹⁾	26	41	60	50	72	98	90	122	160
Polyoximethylene (Polyacetal)	max. g POM	35	55	80	66	96	130	120	163	213
Polyethylene terephthalate	max. g PET	34	53	77	64	92	126	115	157	205
Polyethylene	max. g PE-LD	22	34	49	41	59	80	73	100	130
	max. g PE-HD	22	35	50	42	60	82	76	103	134
Polypropylene	max. g PP	23	36	51	43	62	84	77	105	137
Fluoropolymerides	max. g FEP, PFA, PCTFE ¹⁾	46	72	103	86	124	169	155	211	276
	max. g ETFE	40	63	91	76	109	148	136	185	242
Polyvinyl chloride	max. g PVC-U	35	54	78	65	94	127	117	159	208
	max. g PVC-P ¹⁾	32	50	72	60	87	118	108	147	192

1) average value

ARBURG GmbH + Co KG
 Arthur-Hehl-Strasse
 72290 Lossburg
 Tel.: +49 7446 33-0
 www.arburg.com
 contact@arburg.com