



# PRODUCTION EFFICIENCY

Think holistically – reduce unit costs

**ARBURG**

# PAVING THE WAY

The entire value chain in view.  
For sustainable and  
profit-oriented manufacturing.

For us, production efficiency means: making rational use of resources and exploiting all potential to the maximum. To find the individual solution that is best for you, we take the entire value chain and all influencing factors into account. But there is also a lot that you can optimise in your existing production, often without any additional investment. Take the first step with us – it will be worth it!

**WIR SIND DA.**

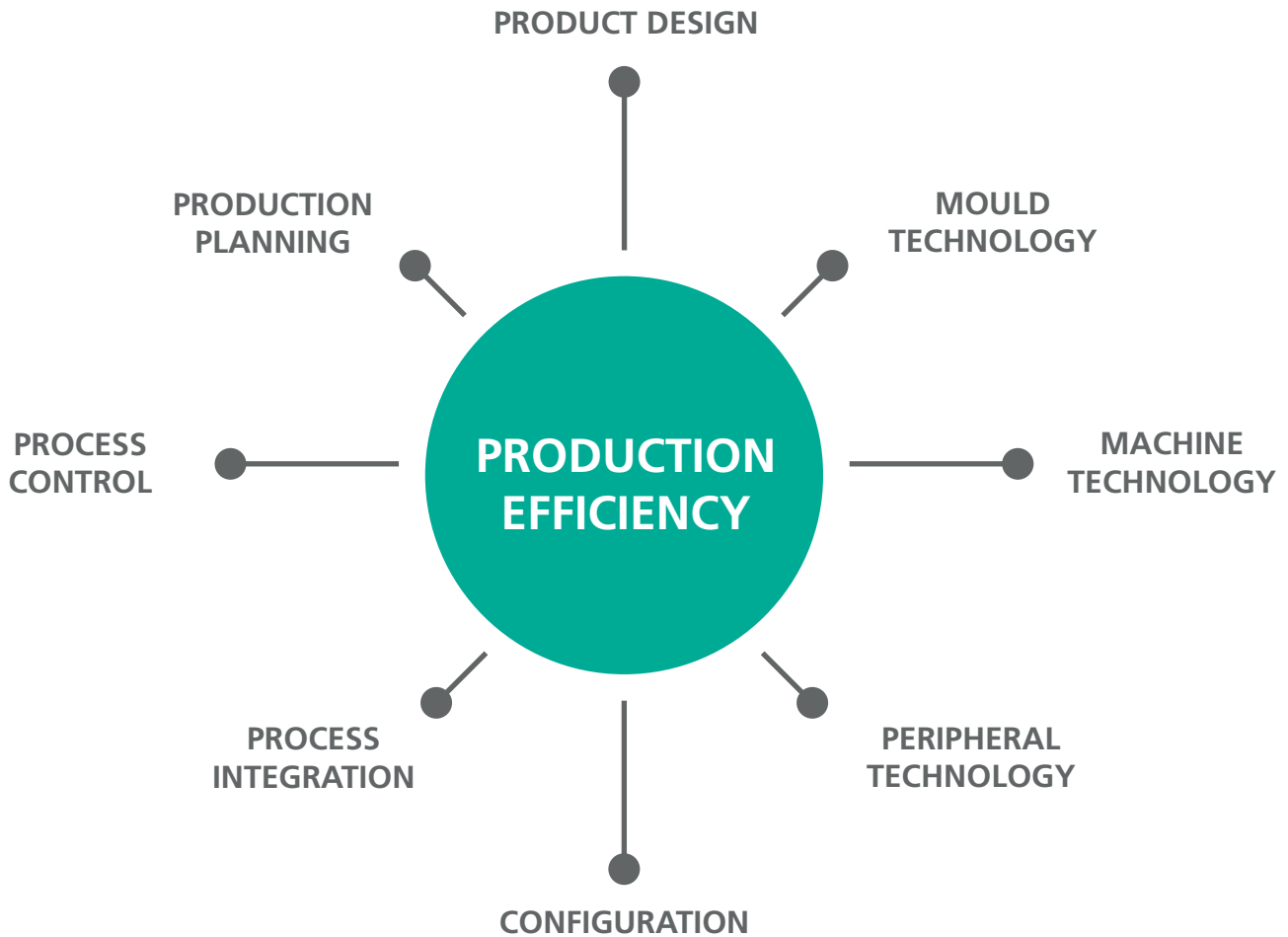

## **GREATER COST-EFFECTIVENESS: ANCHORED IN OUR STRATEGY**

// Our goal is to continually and sustainably increase cost-effectiveness not just in our own company, but also for all our customers. We have been channelling all our efforts in this direction for decades. As system supplier, we offer an entire solutions portfolio from a single source. As technology consultants, we stand by your side with outstanding know-how– at every point along the entire value chain. //

## A holistic view of value creation

In order to fully meet the demands of production efficiency, the entire value chain and all variables should be included – from product design to production planning. Each individual area offers the potential to reduce unit costs on a sustainable basis: by minimising energy requirements, material input, personnel, processing time, production steps, standstill times and rejects. However, there are no one-size-fits-all solutions – each company must find its own path – supported by partners with extensive know-how, such as ARBURG.

## Strategically anchoring production efficiency

An ongoing task to be pursued over the long term: the rational use of all resources. Here, the selection and design of production systems has a major influence on the subsequent efficiency of production. Thus, the planning phase is growing in importance for businesses. Any unforeseen issues at this stage can only be corrected to a limited extent in the production phase and usually only at considerable cost. However, if production efficiency is strategically anchored in the activities of an injection moulding plant from the outset, then such (additional) investments will pay off in a very short time.

We are technology  
and system partners –  
more than

30

A-Z  
YEARS  
OF EXPERIENCE



Profound: practical expertise in all aspects of plastics processing, gathered from first-hand experience.

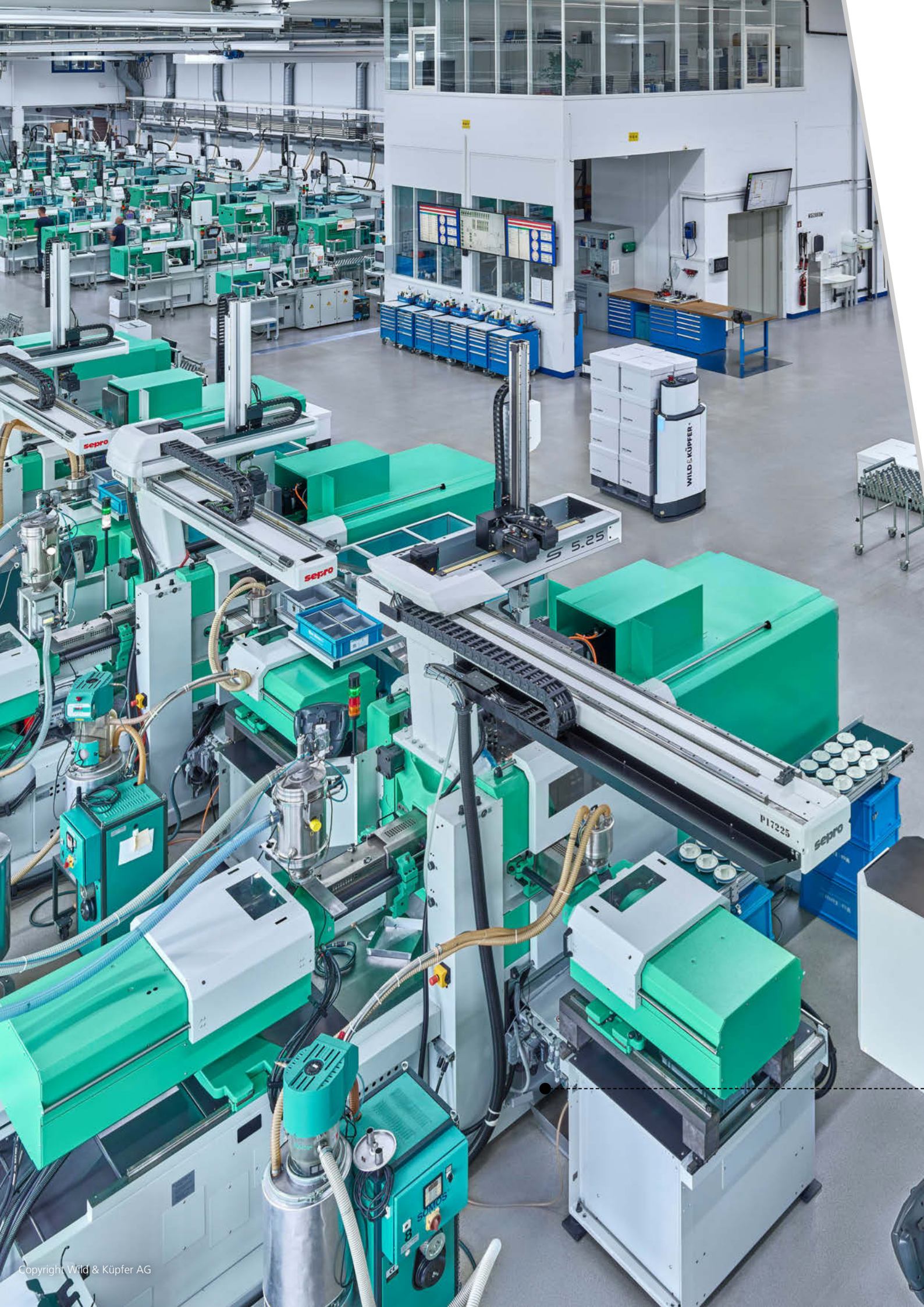

# OUR KNOW-HOW – YOUR SUCCESS!

## **Making the most of ARBURG know-how**

By making use of the interplay between new processes and plastics, as well as innovative machine and system technology, optimal individual solutions are possible. However, this calls for interdisciplinary expertise. Therefore our expertise ranges from machine, robotic, control and process technology, through to IT-networked production planning with data exchange across all levels. Moreover, we have a network of strong partners, such as leading manufacturers of materials and moulds. Tap into this unique pool of knowledge in order to implement efficient complete solutions from a single source.

## **Perfect custom solutions**

Owing to the many influencing factors, working in a truly efficient manner is a genuinely challenging task. Here the most important rule is: high quality at the lowest possible unit costs. Our coordinated product range enables individual solutions for efficient moulded part production. You benefit from modular, scalable and individually combinable components with which you can effectively design and optimise your processes.

## **Getting employees and infrastructure into shape**

In addition to all the technology, people are always a decisive success factor. As a result of the constantly increasing requirements, it is important that the employees' awareness of efficient production is raised as well. In addition, the extended production environment should also be included in your efficiency efforts – for example infrastructure or facility management. This makes it possible to determine additional potential savings. This is another area where we are pioneers – and you profit from our experience.

On all levels: use quantitative potential savings during injection moulding and achieve sustainable reductions in unit costs.

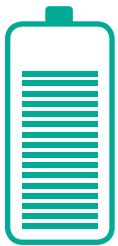

**SAVE**  
**CYCLE TIME AND**  
**PROCESSING POWER**  
with flow-enhanced plastics

Simulation of the flow pattern:  
clarify weaknesses in the product  
design before implementation.

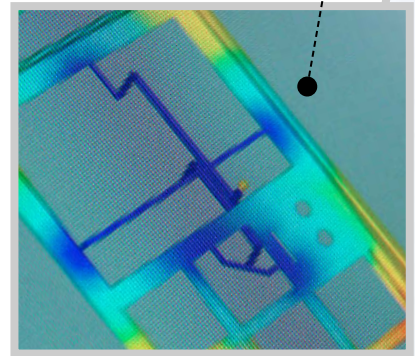

## PRODUCT DESIGN: OPTIMUM COMPATIBILITY

// Efficient production starts with the product design. We can help you to continuously find new, individual solutions. Our approach is a holistic one: because we know what to look for in a design to enable important functions to be integrated into a part, thereby reducing production steps or enabling problem-free automation. We provide you with quick and hassle-free assistance on all aspects of moulded part design and material selection. //



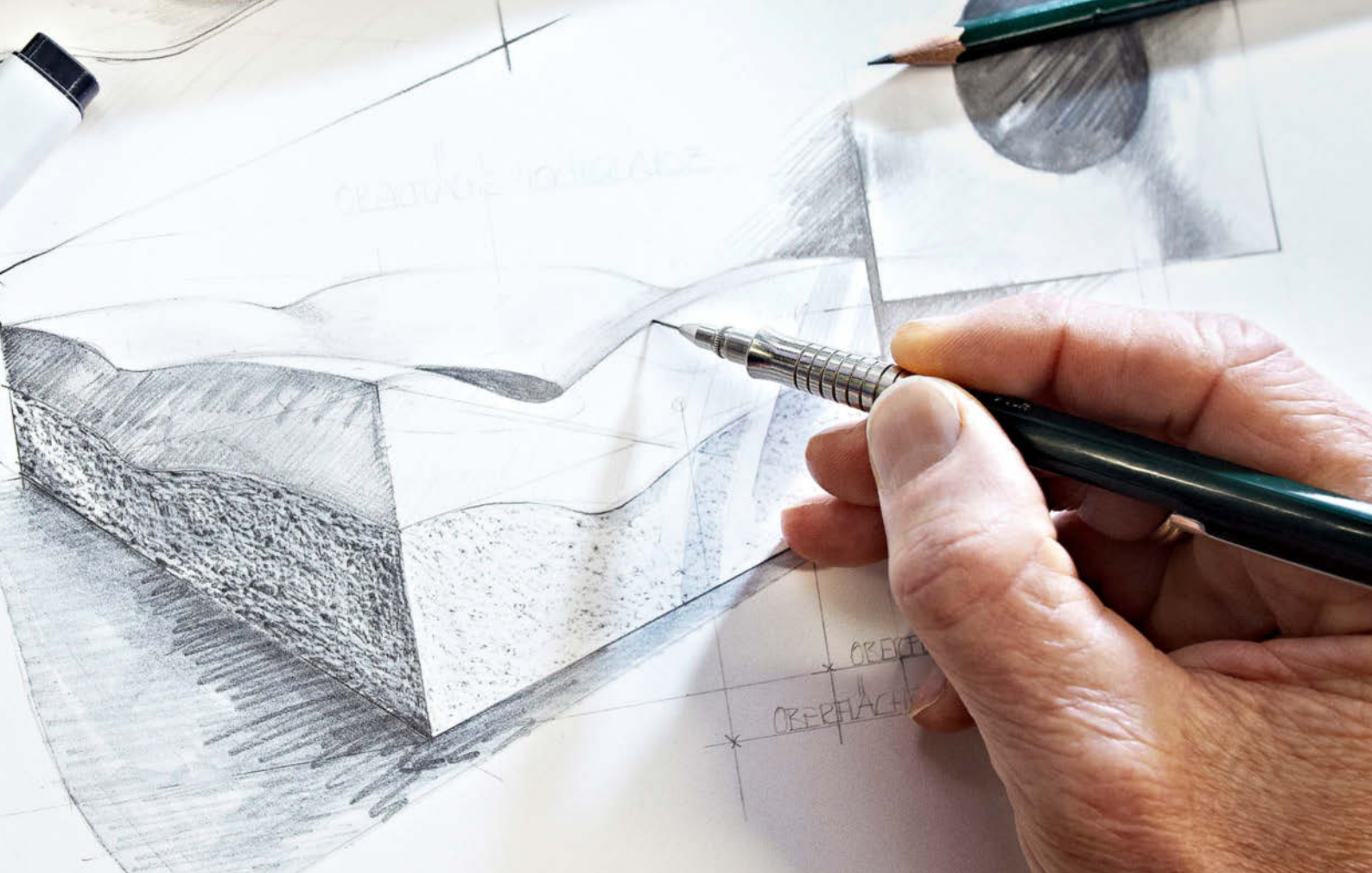

### Reducing material use

Production efficiency starts with product designs that are suitable for the material. This is because material savings lead to greater cost-effectiveness in a number of respects: thinner walls permit shorter cooling and cycle times. For example, designing the parts and tolerances in line with the plastics used ensures good demoulding - that increases the process reliability. Intelligently combining various processes and materials yields additional benefits: Function integration and reduction of production steps.

### Accurate material selection

By selecting the correct plastic, you can set the course for efficient injection moulding production from the outset, together with our help. A fundamental aspect is the dependence on the energy requirements for melting the plastic used. Production conditions, which may necessitate the use of interior air conditioning, for example, must also be taken into consideration. All these factors impact on your overall production process. Our high competence in consulting gives you the ability to explicitly match the product requirements and the material characteristics.

**i** / Further information:  
Application expertise brochure

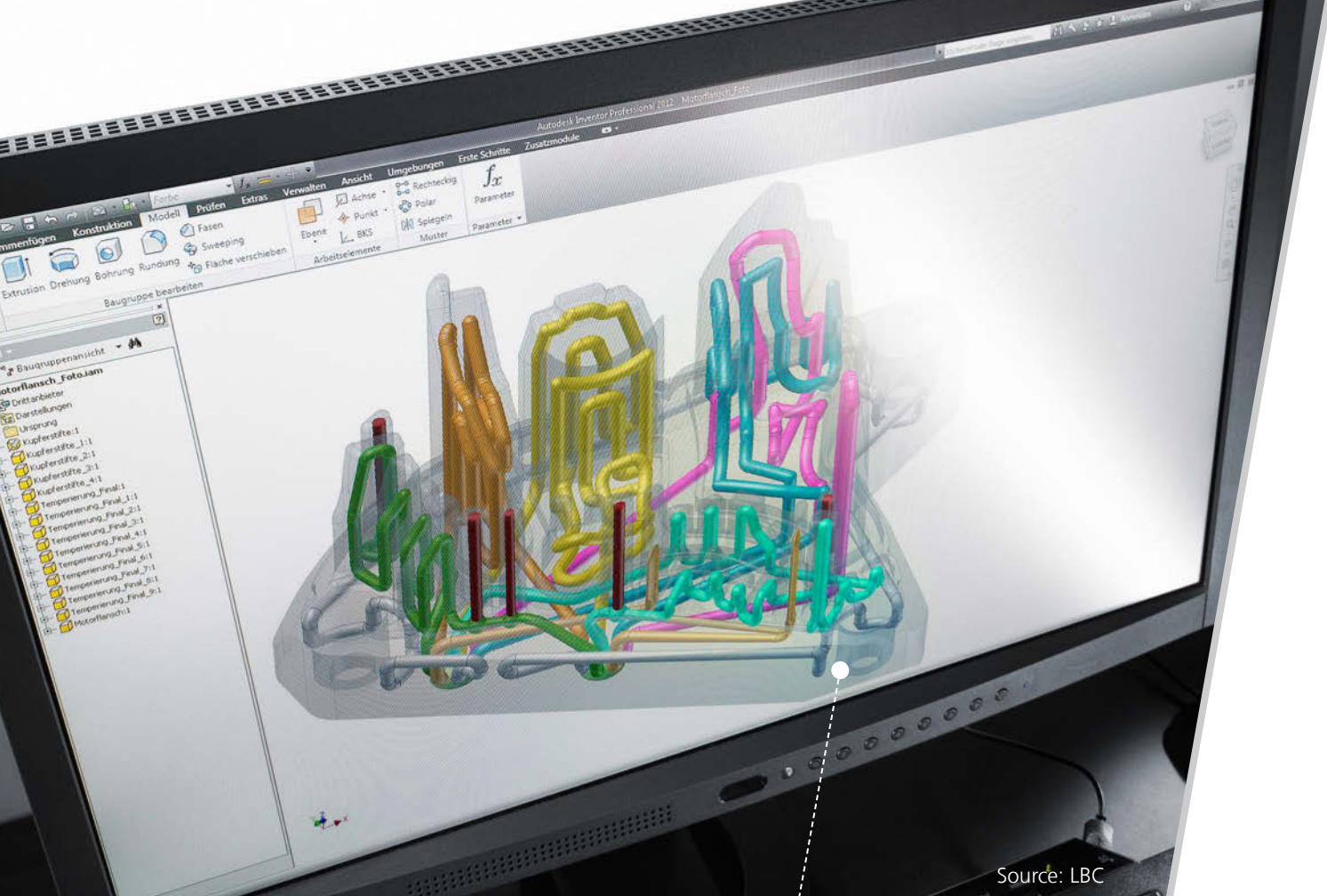

Source: LBC

Near-contour mould temperature control reduces the cycle time and ensures high process control capability.

## MOULD TECHNOLOGY: ACCURATELY IMPLEMENTING DETAILS

// You can only achieve perfect quality and output if a precise approach has been taken for each detail when designing and implementing the mould. In the final analysis, this also means that mould and injection moulding technology need to be coordinated in detail. We use our interdisciplinary expertise and close cooperation with technology leaders in the field of mould construction to continuously develop new solution approaches – for your efficient plastic processing. //

# WE INCREASE YOUR POTENTIAL FOR REDUCING UNIT COSTS.

## Targeted optimisation with simulations

The mould technology plays a crucial role for consistent product quality at the shortest possible cycle times. We can offer you detailed advice for targeted optimisation on the basis of computer-aided simulations. Thus you can prevent distortion of parts or inadequate filling of the mould, for example. Effective measures for reducing the energy consumption and cycle time are, among others:

- Segmented mould temperature control
- Temperature-control channels close to the cavity
- The right temperature-control medium
- Generously sized medium runners
- Short supply lines

## Thermal mould design

The mould temperatures and cooling water quantities should be accurately matched to the respective application. For example, if the inflow temperatures of the cooling system can be increased without affecting the injection moulding process, considerable operating cost savings can be achieved. The improvement in water quality also ensures free pipe cross-sections and therefore lower energy costs. Economical mould temperature control also enables stable processes and thus leads to a reproducibly high part quality.

**AROUND 50% LESS**

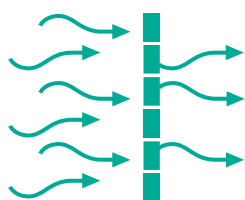

# LOSS OF ENERGY

e.g. by insulating hot mould parts



# MACHINE TECHNOLOGY: ACCURATELY FINE-TUNED

// The running costs and performance should always be taken into consideration when deciding for or against investing in a particular machine concept. Here we can provide you with detailed and future-oriented advice – because machine technology has been our core competence for more than 60 years. We have the right solution for each injection moulding task. This is guaranteed by our seal of quality - Made by ARBURG - Made in Germany. //



# freeformer 200-3X



reddot award 2014  
winner

ARBURG  
ALROUND 20'S

Compared to a standard hydraulic machine, up to



**2 s**  
**SHORTER**  
DRY CYCLE TIME



## Focusing on performance

The drive system has a major influence on energy efficiency and cycle time. Electric drives score highly here with their energy-saving, fast and simultaneous movements, as well as braking energy recovery. In the case of hydraulic systems, short cycle times can be achieved by means of multi-pump or hydraulic accumulator technology, for example. Energy requirements are

reduced through the use of IE3 motors or efficiency-optimised hydraulic drives. An electric injection moulding machine may not always represent the most cost-effective solution. It is always recommended to perform a detailed analysis of the relevant application and its production parameters. We can provide you with support on this as well.

## Evaluating economic feasibility

The key to the most efficient solution: individually combining various drive concepts. With our module product range, you are always flexible. To find the best solution for your application, we calculate the unit costs and take all important parameters into account. This makes the influence of factors such as productivity and energy

requirements clear, and you can assess the amortisation periods for more sophisticated machine technology. Time and time again, these analyses have shown: shortening cycle times has the greatest impact on reducing unit costs and therefore on the cost-effectiveness of moulded part production.

Synchronous ejection:  
simultaneous sequences  
reduce the cycle time.

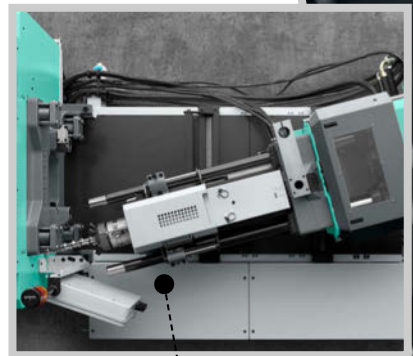
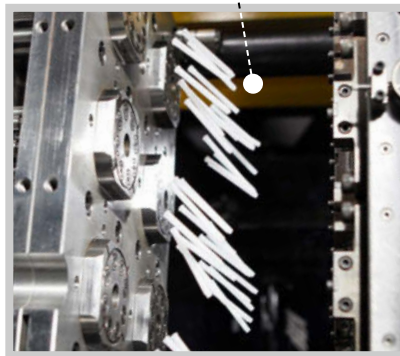

Practical relevance in every detail:  
Our sophisticated technology offers you all  
the freedom required for efficient operation.

**i** / Further information:  
Products and services brochure



# PERIPHERAL TECHNOLOGY: MAKING ACCURATE CHOICES

// Production efficiency is achieved when all areas complement each other and produce a successful whole. Therefore the production environment has to match the mould and machine technology. We always adapt our complete solutions to your precise needs. This is made possible by our wide range of products, practical configuration options and, last but not least, far-reaching integration that enables you to manage and synchronise sequences on a centralised basis. This allows you to get the best out of all your applications. //



Standardised interfaces: simplify integration of peripheral equipment into robot cells.



Adapted material feed: smooth production with a high degree of autonomy.



INTEGRALPICKER with fast mould-entry axis for **20 m/s<sup>2</sup>** ACCELERATION

## Ensuring ease of operation

Where peripheral components are concerned, speed-regulated electric drives offer significant benefits for cycle time reduction, higher precision and energy efficiency. Central control and monitoring of all the peripheral equipment by the intuitive ARBURG machine controller is a further convenience. That saves time in the programming and monitoring of the system. And it has a positive effect on the cost-efficiency of the entire production process.

## Holistic view of the environment

You can effectively reduce heat and particle immission into the production environment by means of water-cooled component assemblies such as hydraulic power units and motors. Depending on the production conditions, for example in clean rooms, this can be of crucial importance. Our carefully tailored accessories, such as quick-connect systems for the moulds, automatic feeders, or unscrewing units help you to always produce to the highest quality. This is because all our products fit together to perfection.

**i** / Further information:  
robotic systems brochure

# CONFIGURATION: PRODUCT-SPECIFIC

// Efficient production is only possible if the system is perfectly tailored to the respective application. As early as the planning for purchasing a system, we develop a concept together with you that is fine-tuned to the last detail. This makes it easier for you to choose the right product, and your injection moulding technology will work just as you want it to right from the start. Efficient and reliable - just as you'd expect from us. //

Wide range: we offer you machines with clamping forces from 125 to 6,500 kN.



International technical support: our experts in the field of application technology can also advise you on site.

**i** Further information:  
Application expertise brochure

## Individual configuration

Efficient injection moulding means: all components have been chosen with care and offer just the right cycle time and energy efficiency for the task. Our extensive range of expansion stages and equipment lets you flexibly adapt the machine sizes and injection processes. Particularly interesting: the extensive range of options for combining clamping and injection units, plus the appropriate drive system. And it means that for every requirement, you can create a combination that functions perfectly in terms of energy and the technical process.

## Optimal consulting

Our application engineers provide you with professional support in selecting the right configuration. In interdisciplinary teams, we discuss and evaluate each production concept and create thermal process assessments or individual energy analyses for you. Our intelligent ARBURG know-how database contains decades of experience of our experts and the information can thus be accessed quickly all across the world. Additionally, our Customer Center provides the perfect environment for in-depth testing and trials.

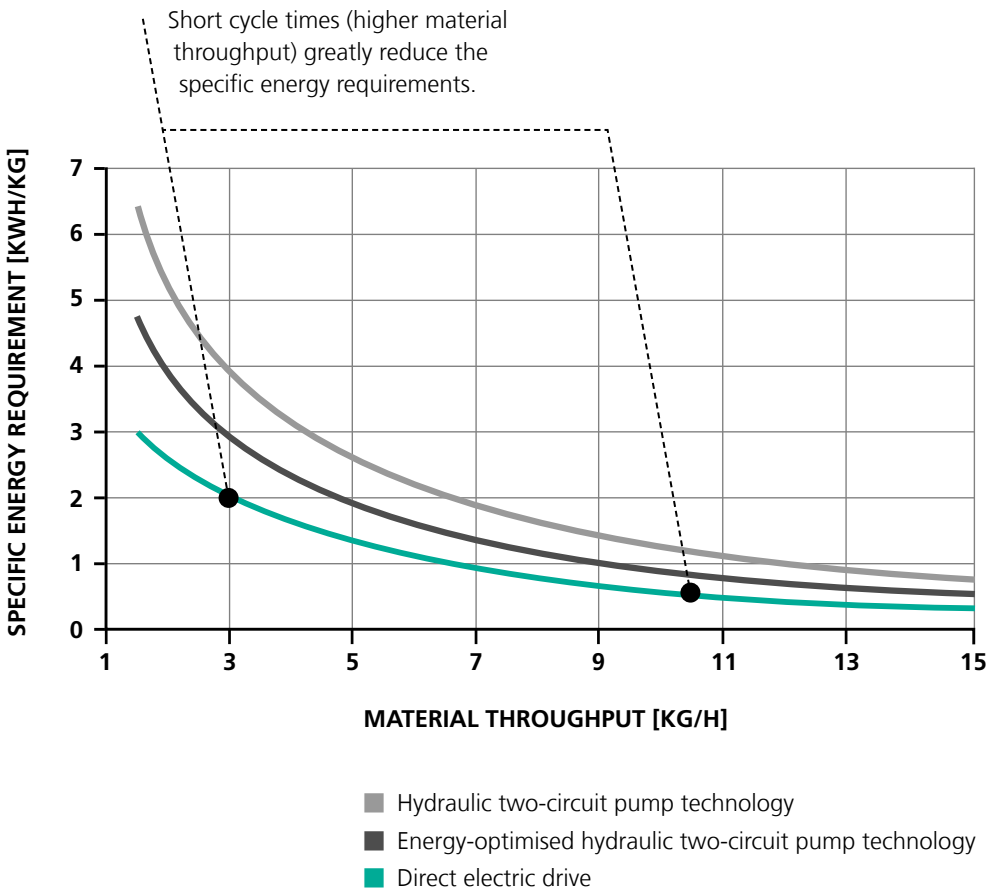

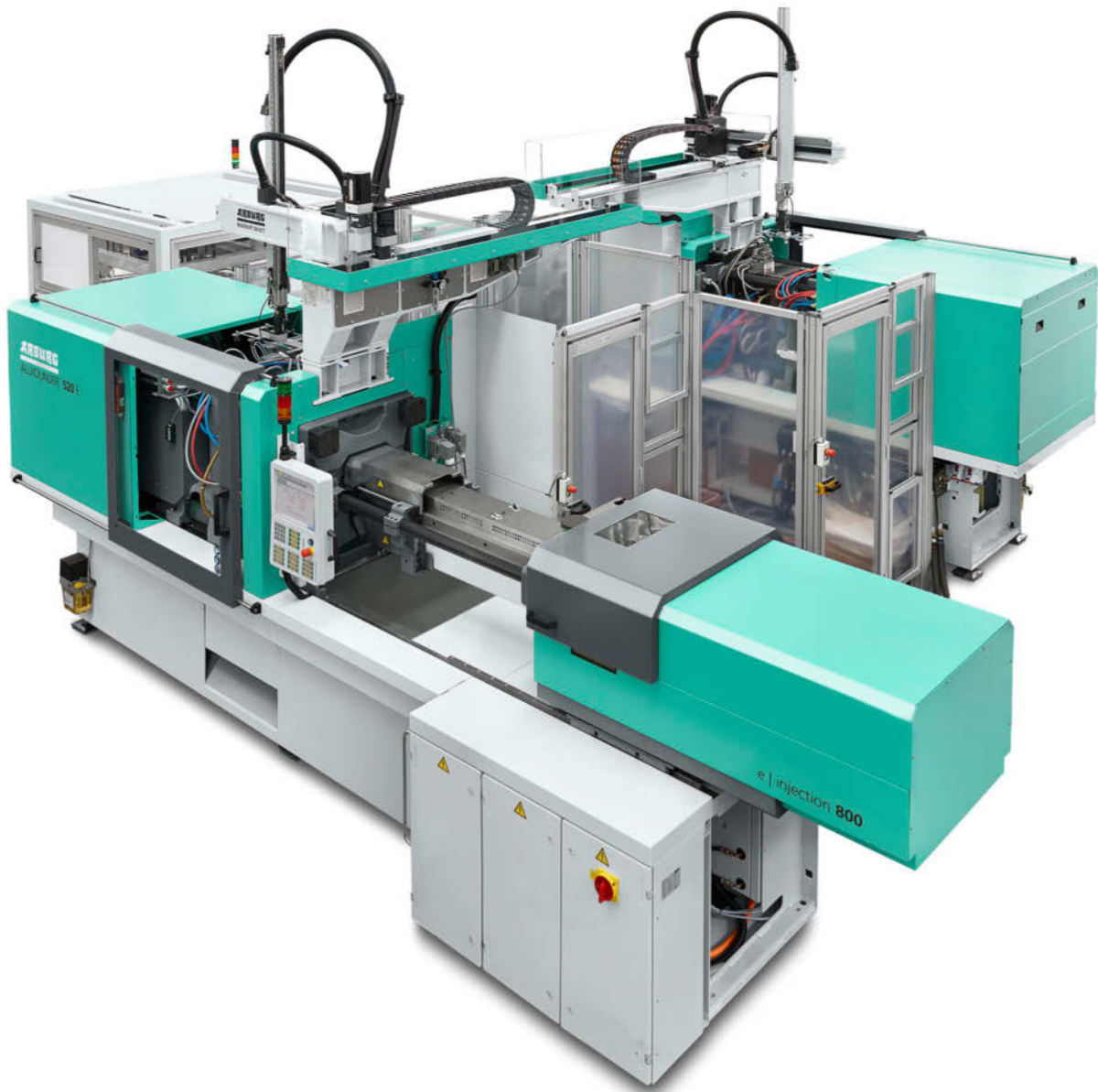

## PROCESS INTEGRATION: REDUCING PROCESS STEPS

// Looking to further increase the efficiency with regard to your injection moulding process? We can offer you wide-ranging expertise for the automation and integration of even complex process steps. Several hundred individual turnkey systems go into operation each year, with ARBURG acting as the primary contractor that provides complete systems. Your advantage: You receive all the system technology, know-how, consulting and service from a single source. //

## Rational integration of automation and inline processes

Integration of upstream and downstream process steps increases the efficiency of your entire production. Manual work is reduced, logistics optimised and the productivity thus increased sustainably. Integration begins with the automatic provision of inserts and ranges from fast part removal to inline quality assurance, further processing and sales-ready packaging.

## Efficient solution as objective

Are you looking for an efficient turnkey solution that is as uncomplicated as possible? You just need to cooperate with our extremely well trained turnkey experts. We rely on a networked approach based on the "second pair of eyes principle". Every concept and every design is discussed and evaluated in brainstorming teams - enabling us to fully exploit our experience and creativity for every task.

## Precision landing as result

We offer comprehensive project management that ensures the delivery of the complete turnkey system on the agreed date. As this is pre-tested by us under production conditions and process sequences are optimised, you can expect fast production readiness. This is also ensured by our highly trained technical specialists, who have solid expertise both in automation technology and injection moulding technology.

Comprehensive management:  
we also take care of peripheral  
equipment control and data exchange.





# PROCESS CONTROL: WORKING TO A HIGH QUALITY STANDARD

// Complex requirements can be handled with ease! Your operators need to be able to adjust and control production processes intuitively, however complex they may be. What is required is a “smart machine”, which integrates your peripheral equipment trouble-free, supports you actively in all operating situations, as well as monitoring and adaptively controlling your process. This is precisely the aim of many of our control system features: For greater productivity. For higher process reliability. For better part quality. For fault-free operation. In other words: for more value all-round! //

**i** / Further information:  
GESTICA brochure

## Efficient control

A reproducible, consistent injection moulding process is a prerequisite for high quality. That is why you need a machine controller that can be tailored precisely to your requirements. This enables you to synchronise injection moulding machine and peripheral equipment, to optimise sequences and to monitor the quality continuously – for stable production.

## Efficient monitoring

To achieve more productivity, high process reliability and transparency, uniform and all-embracing injection moulding management. This enables you to interlink robotic systems and peripheral devices in standardised networks, and use these to centrally and easily control entire production cells. Additionally, process data management and set-up tasks become easier and safer.

## Efficient operation

You want to extensively interlink your production, adaptively regulate your processes and have a control system that actively supports you in all operation situations? All of that is possible with a “smart machine” – from set-up and start-up, through optimisation and production, to monitoring and service. This drives the digital transformation of your production forward in a targeted manner.

### ASSISTANCE PACKAGES FOR GREATER EFFICIENCY



#### 4.set-up

Guided set-up: You receive active support during set-up and parameter input, leaving you more time for productive tasks.



#### 4.start-stop

Fast production start-up: start-up and shut-down of complex processes are made easier for you, reducing the number of start-up parts required.



#### 4.optimisation

Assured quality and productivity: Allows you to get even more out of your machine in each case - because every split second counts.



#### 4.production

Greater programming freedom: Special processes become standard for you and even complex moulds can be quickly mastered.



#### 4.monitoring

Controlled system status: Comprehensive monitoring functions enable you to detect deviations early and seamlessly document them.



#### 4.service

Time-saving online support: Have faults analysed quickly, efficiently and safely in a remote process – for even greater machine availability.



# PRODUCTION PLANNING: OPTIMUM UTILISATION OF RESOURCES

// Effective production planning plays a central role in efficient and flexible production. This can only be achieved by taking a holistic view of production in its entirety, far beyond the scope of the mere system technology. Only thus can you detect potential for rationalisation and can use synergy effects in ways that make sense. We assist you with proprietary software solutions that adapt to your products and on which you can rely at all times. //

**i** / Further information:  
Host computer system brochure



Fine planning: optimum utilisation of available resources.

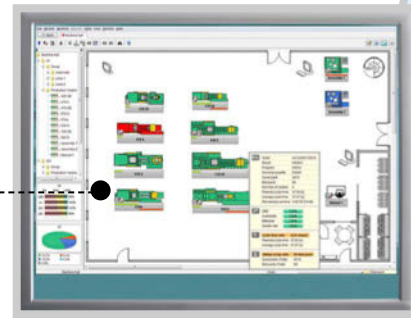

## Rational organisation

You can only flexibly react to constant changes in requirements if there is an efficient data exchange between all production components. The prerequisite for this is extensive data integration in production. So that you can efficiently use the available resources!

## Central management

To plan accurately and continuously optimise the plans, you need reliable information. Process data is captured online, transparently prepared and shared across the network. This enables you to plan down to the minute, optimise sequences and reduce set-up times.

## Maximisation of availability

An integrative and interactive order planning protects you against unscheduled machine downtimes, for example by triggering provision of the setting data, moulds and materials required for production. This makes production intelligent.

By eliminating manual data entry on 20 machines around

**1,250 h**  
OF WORKING TIME  
SAVED PER YEAR





# APPLICATIONS: EFFICIENT

// Our declared goal is to continually increase efficiency and cost-effectiveness not just in our own company, but also for all our customers. Our support encompasses much more than only the machines. As technology partner and system supplier, we offer you outstanding expertise throughout the entire value chain. //

Efficient planning: perfect preparation reduces distances walked during set-up and thus minimises standstill periods.

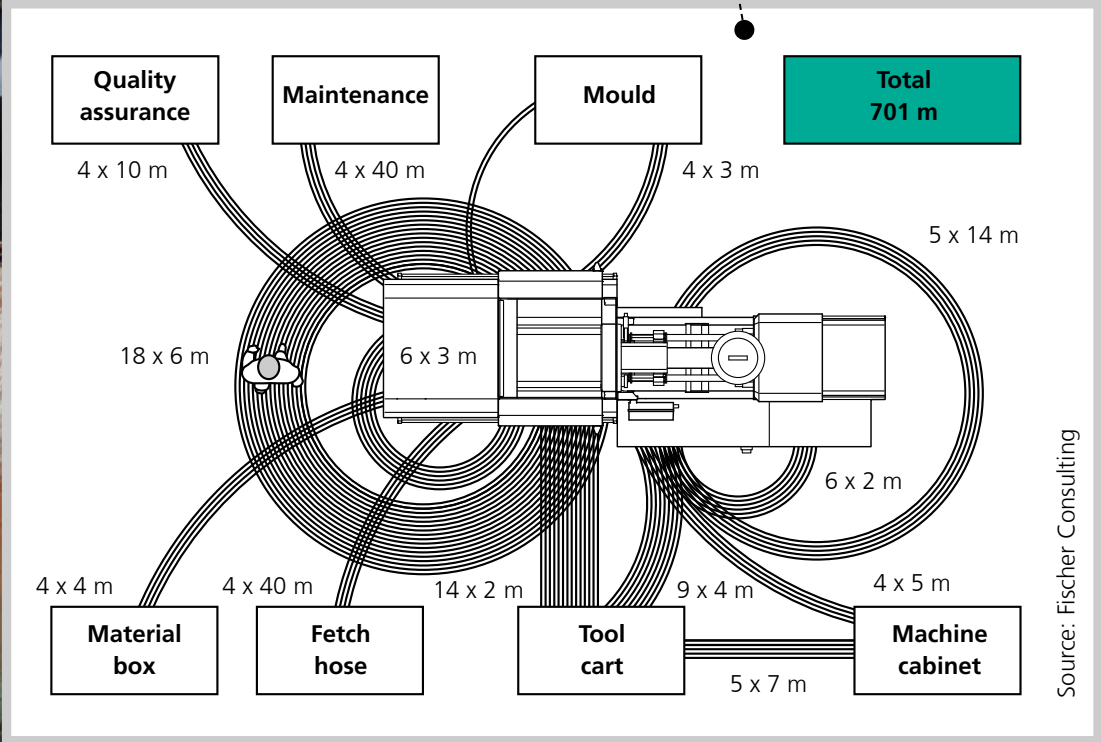

Source: Fischer Consulting

## Integrating components

Perfect interplay between the robotic system and injection moulding machine can save real money. An example: The machine controller of our ALLROUNDER makes it possible to synchronise the ejector and X-axis and to start the Y-axis when the mould opens. Additionally, it is possible to move the ejector to the intermediate stop. This makes your production process much faster and more economical.

## Integrating orders

Multi-variant and economical production – flexible automated injection moulding production makes it possible. As our application example of elastic tension belts impressively shows, the OPC UA communication protocol can be used to integrate customer wishes online into the ongoing injection moulding process – production “on demand”.

## Integrating employees

For process optimisation, people are always a decisive success factor. For example, at ARBURG, video analysis has proven to be a valuable tool for optimising set-up processes. At a turning and milling machine, the sequences for mould changes were improved and set-up times halved. Additionally, the employees are actively incorporated into optimisation processes and their awareness for the topic of efficient production is increased.

Flexible production: customer order data is transmitted directly to the machine controller via OPC UA.



Fully integrated: dynamic robot sequences synchronised with the mould are highly productive.



Scan this code to visit our  
Media Centre: in-depth,  
captivating, entertaining.

**ARBURG GmbH + Co KG**  
Arthur-Hehl-Strasse  
72290 Lossburg  
Tel.: +49 7446 33-0  
[www.arburg.com](http://www.arburg.com)  
[contact@arburg.com](mailto:contact@arburg.com)

**WIR SIND DA.**