

630 A 2500 – 1300

Leisure

- 630 A 2500 – 800 Comfort+
 - Part Willi05
 - Cavities 1
 - Cycle time 60s
 - Material Copolyester, Tritan TX1501HF
 - Shot weight 130g
- Highly transparent material for food contact
 - Bisphenol A free



630 A 2500 – 1300

Highlight

- Clearer, stronger and more durable 'glass'
 - Tritan™ Renew - 100% Bisphenol A free
 - Crystal clear transparency for food contact
 - Extremely durable and resistant to odour, taste, abrasion and breakage
 - Recycled content of 50%
 - Discharge of disposable waste from landfill sites
 - Offsetting the use of fossil resources



630 A 2500 – 1300

Highlight

- Comfort+
 - Machine performance adapted to the requirements of the application
 - Slim design focusses on narrow machine width
 - Automation via MULTILIFT SELECT 16

→ **More performance per m²**

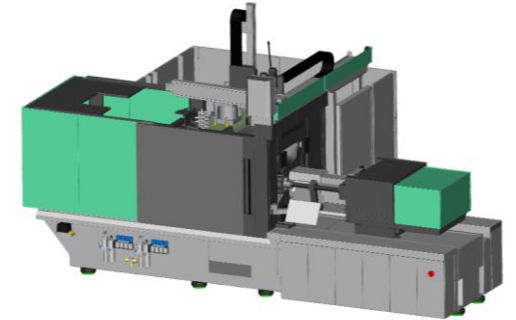

630 A 2500 – 1300

Highlight

- FillAssist
 - Quickly and safely to the first good part
 - 40 % time saving during set-up
 - No simulation software or prior knowledge required
 - Presetting of parameters

→ **Visualise the filling process - faster to the good part**

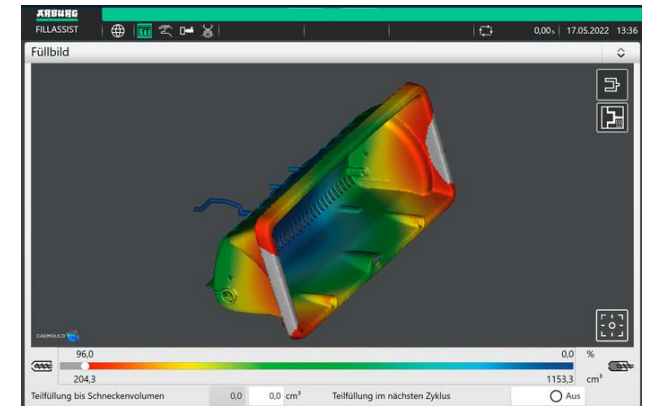

630 A 2500 – 1300

Production cell automation

- Sequence
 - Part removal with MULTILIFT SELECT 16
 - Handover to hot stamping (A)
 - Set down finished part and handout via conveyor belt (B)

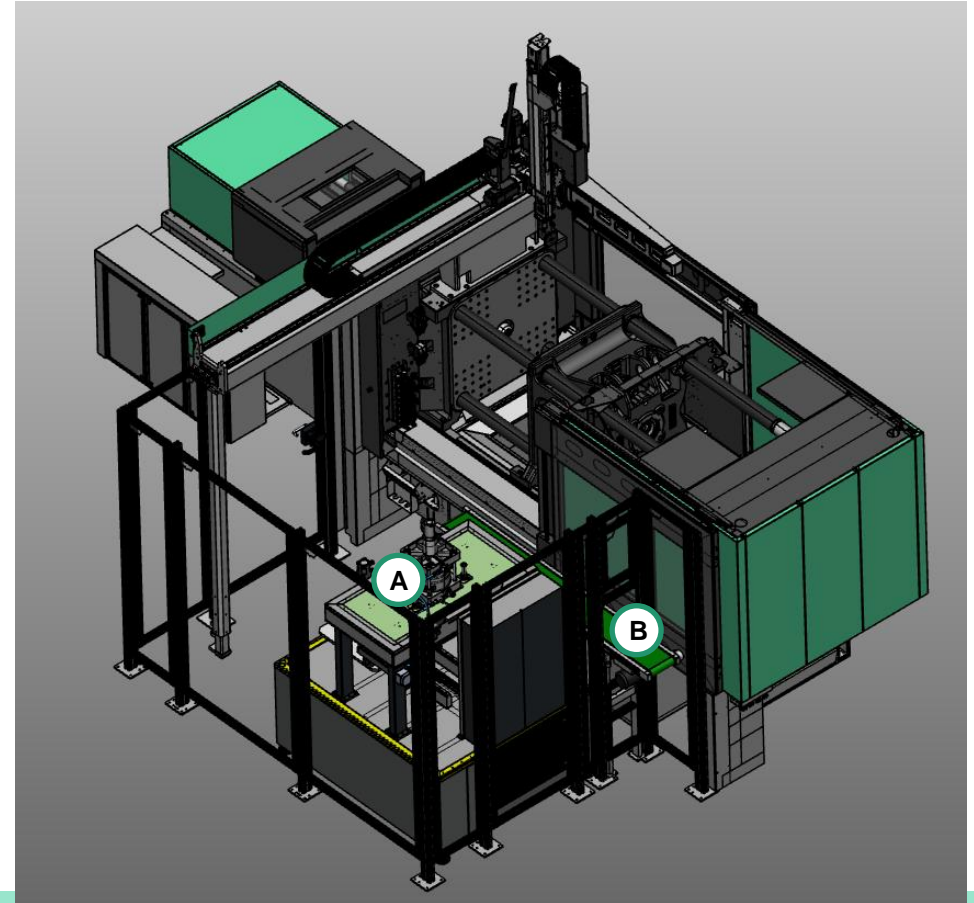

630 A 2500 – 1300

- Allrounder 630 A 2500 – 800 Comfort +
 - Partner
 - Mold Adoma GmbH, D
 - Material IMCD Deutschland GmbH, D
Eastman Chemical Company
 - Hot stamping LEONHARD KURZ Stiftung & Co. KG, D
Baier GmbH & Co. KG Maschinenfabrik, D
 - EOAT Barth Mechanik GmbH, D
 - Conveyor belt SCHUMA Maschinenbau GmbH, D