

## ALLROUNDER 570 S

Distance between tie bars: 570 x 570 mm

Clamping force: 1600, 2000, 2200 kN

Injection unit (acc. to EUROMAP): 400, 800, 1300

**ARBURG**

# MACHINE DIMENSIONS | 570 S

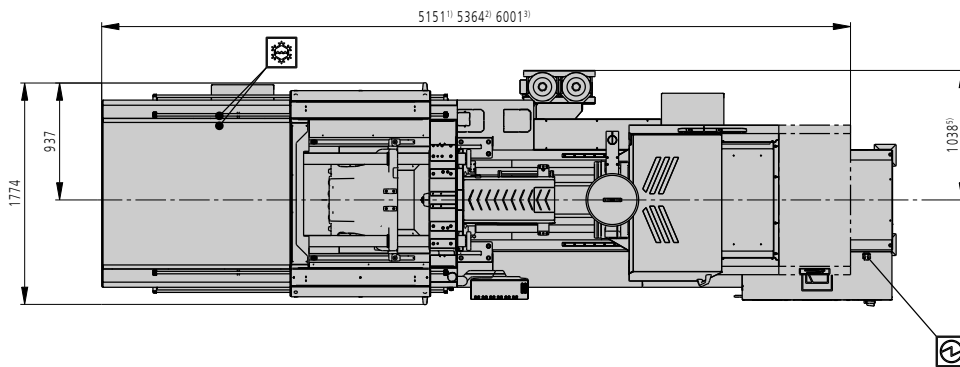
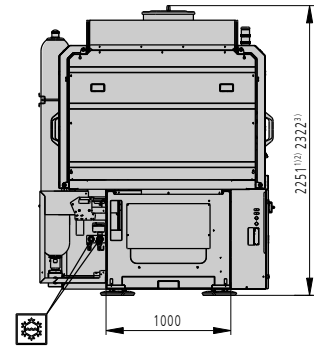
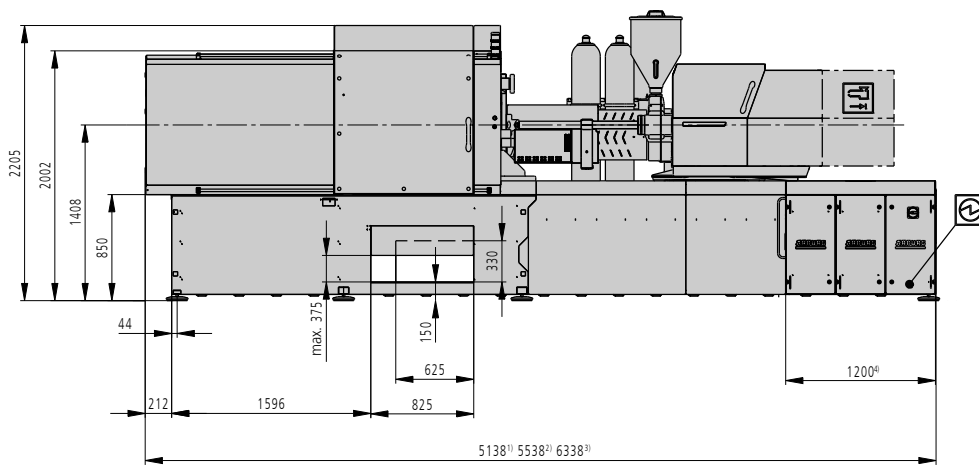

Electrical connection



Cooling water connection

- 1) Injection unit 400
- 2) Injection unit 800
- 3) Injection unit 1300
- 4) Subject to performance variant and injection unit size
- 5) Accumulator

# TECHNICAL DATA | 570 S

Clamping unit			570 S		
with clamping force	max. kN		1600	2000	2200
Opening force   stroke	max. kN   mm		520   650		
Mould height, fixed   variable	min. mm		250   ---		
Platen daylight fixed   variable	max. mm		900   ---		
Distance between tie bars (w x h)	mm		570 x 570		
Mould mounting platens (w x h)	max. mm		795 x 795		
Weight of movable mould half	max. kg		1400		
Ejector force   stroke	max. kN   mm		70   200		
Dry cycle time EUROMAP <sup>2</sup>	1 pump	min. s - mm	3,1   2,8 - 399		
	2 pumps	min. s - mm	2,4 - 399		
	Accum.	min. s - mm	2,3 - 399		

Injection unit			400			800			1300		
with screw diameter	mm		35	40	45	45	50	55	55	60	70
Effective screw length	L/D		23	20	18	22	20	18	22	20	17
Screw stroke	max. mm		160			200			240		
Calculated stroke volume	max. cm <sup>3</sup>		154	201	254	318	392	474	558	664	904
Shot weight	max. g PS		141	184	232	291	359	434	510	607	826
Material throughput	max. kg/h PS		25	29	35	46	53	59	86	96	115
	max. kg/h PA6.6		12,5	15	17,5	23	27	30	43	48	58
Injection pressure	max. bar		2500	2000	1580	2470	2000	1650	2380	2000	1470
Holding pressure	max. bar		2500	2000	1580	2470	2000	1650	2380	2000	1470
Injection flow <sup>2</sup>	1 pump	max. cm <sup>3</sup> /s	128	168	212	138	170	208	---		
	2 pumps	max. cm <sup>3</sup> /s	128	168	212	138   174	170   214	208   260	238	284	388
	Accum.	max. cm <sup>3</sup> /s	492	642	814	530	656	792	714	848	1156
Screw circumferential speed <sup>2</sup>	1 pump	max. m/min	47	53	60	45	50	60	---		
	2 pumps	max. m/min	52	60	67	45   54	50   60	55   66	40	43	51
	Accum.	max. m/min	16	19	21	15	17	19	19	21	25
Screw torque	max. Nm		480	550	610	880			1510	1640	1920
Nozzle contact force   retraction stroke	max. kN   mm		60   400			70   400			90   550		
Heating capacity   zones	kW		9,4   5			19,9   8			22,9   8		
Feed hopper	l		50			50			50		

Drive and connection			1 pump		2 pumps			Accum.		
with injection unit			400	800	400	800	1300	400	800	1300
Net weight of machine	kg		8350	8650	8350	8650	9850	---		
Sound press. level   Insecurity <sup>4</sup>	dB(A)		70   3		70   3			70   3		
Oil filling	l		260		260	260	390	360	360	---
Drive power <sup>2</sup>	max. kW		30	30	30	30	37	22	30	30
Electrical connection <sup>3</sup>	kW		34	53	42	53	63	34	53	55
	Total	A	80	125	100	125	125	80	125	125
	Machine	A	---		---			---		
Heating	A	---		---			---			
Cooling water connection	max. °C		25		25			30		
	min. Δp bar		1,5   DN 25		1,5   DN 25			1,5   DN 25		

Machine type	
with EUROMAP size designation <sup>1</sup>	Drive
570 S 1600-400   800	1   2   Accum.
570 S 2000-400   800	1   2   Accum.
570 S 2200- ---   800   1300	-   2 pumps

### Upon request: other machine types and mould installation heights, screws, drive powers etc.

All specifications relate to the basic machine version. Deviations are possible depending on variants, process settings and material type. Depending on the drive, certain combinations, e.g. max. injection pressure and max. injection flow may be mutually exclusive.

- 1) Clamping force (kN) - size of injection unit = max. stroke volume (cm<sup>3</sup>) x max. injection pressure (kbar)
  - 2) Specifications depend on the drive config. - 1st value applies to the lowest clamping force.
  - 3) Specifications relate to 400 V/50 Hz.
  - 4) Detailed info in the operating instr.
- [ ] Specifications apply to alternative equipment.

# MOULD INSTALLATION DIMENSIONS | 570 S

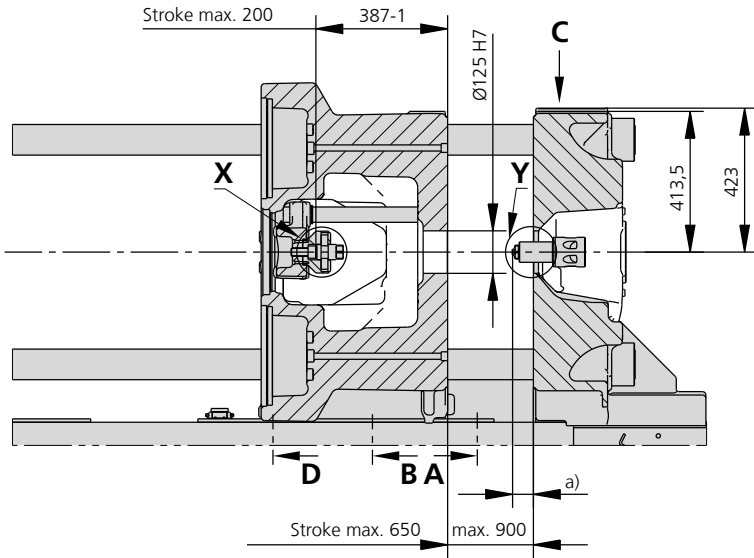

a max.	Injection unit	
	400 / 800	1300
Standard	50	60

## Ejector bolt | X

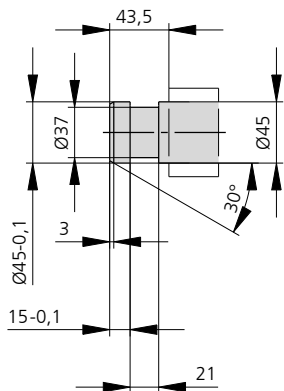

## Bore in mould (if required) | Y

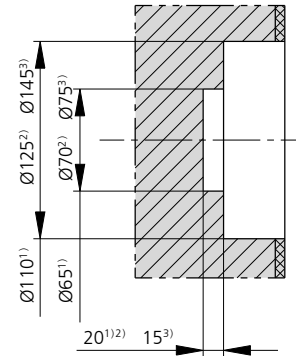
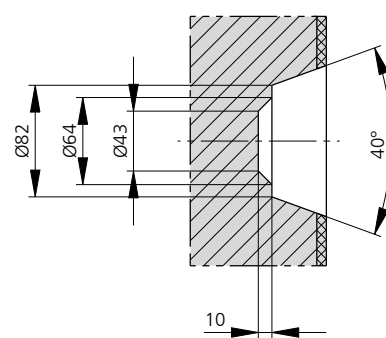

for injection unit 400<sup>1)</sup> / 800<sup>2)</sup> / 1300<sup>3)</sup>  
Thermoset version

## Robotic system mounting | C

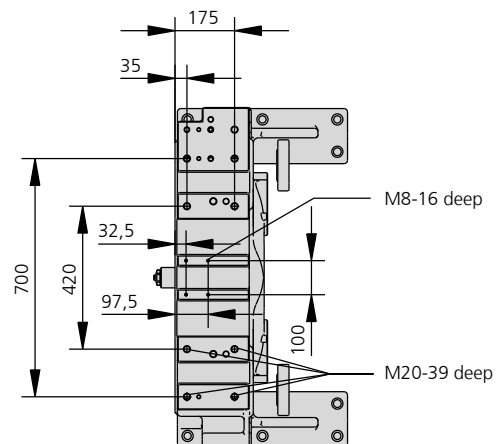

# MOULD INSTALLATION DIMENSIONS | 570 S

## Fixed mould mounting platen | A

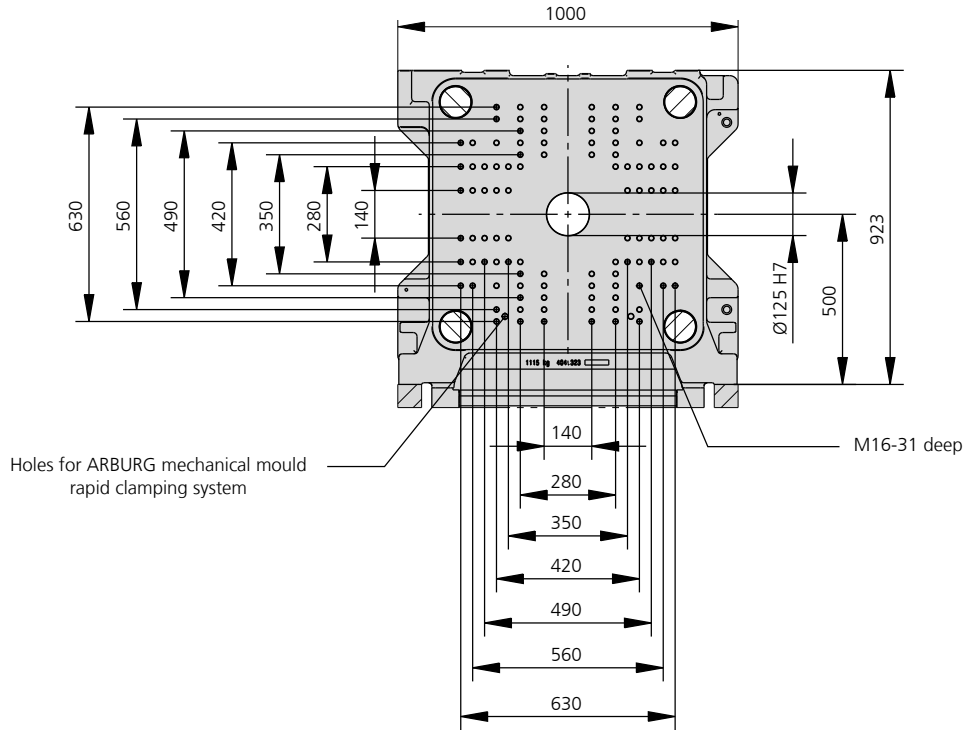

## Moving mould mounting platen | B

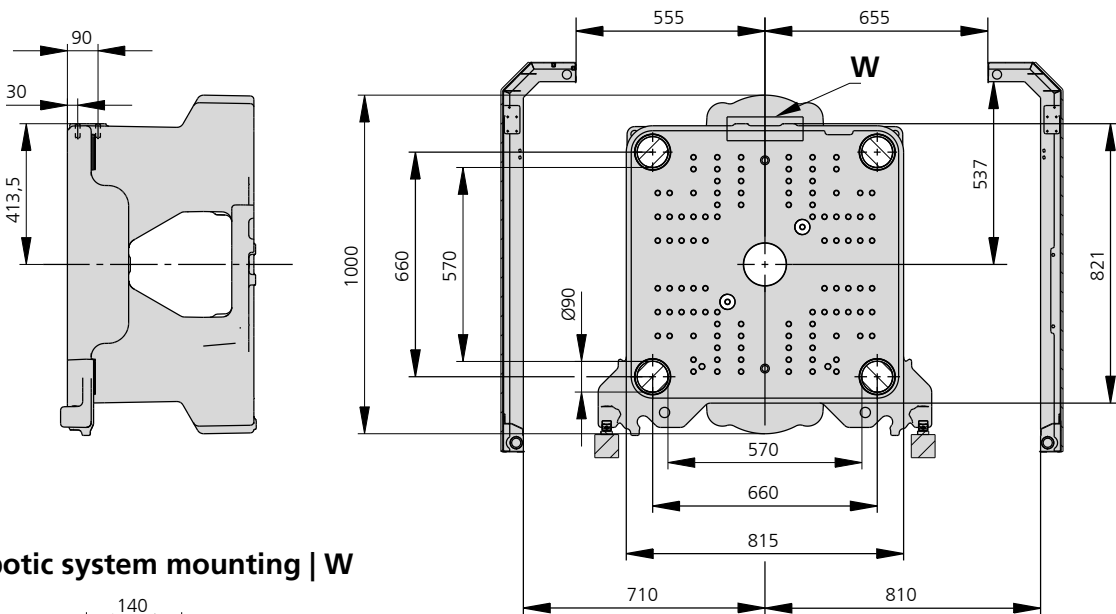

## Robotic system mounting | W

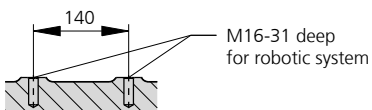

# SHOT WEIGHTS | 570 S

## Theoretical shot weights for the most important injection moulding materials

Injection units according to EUROMAP		400			800			1300		
Screw diameter	mm	35	40	45	45	50	55	55	60	70
Polystyrene	max. g PS	141	184	232	291	359	434	510	607	826
Styrene heteropolymerizates	max. g SB	137	179	227	284	350	424	498	593	807
	max. g SAN, ABS <sup>1)</sup>	135	176	223	278	344	416	488	581	791
Cellulose acetate	max. g CA <sup>1)</sup>	158	207	262	327	404	488	574	683	930
Celluloseacetobutyrate	max. g CAB <sup>1)</sup>	147	192	243	304	375	454	534	635	865
Polymethyl methacrylate	max. g PMMA	145	190	240	300	371	449	527	627	854
Polyphenylene ether, mod.	max. g PPE	131	171	216	270	333	403	473	563	767
Polycarbonate	max. g PC	148	193	244	305	377	456	536	638	868
Polysulphone	max. g PSU	153	199	252	316	390	471	554	659	897
Polyamides	max. g PA 6.6   PA 6 <sup>1)</sup>	140	183	231	289	357	431	507	603	821
	max. g PA 6.10   PA 11 <sup>1)</sup>	131	171	216	270	333	403	473	563	767
Polyoximethylene (Polyacetal)	max. g POM	174	227	287	359	443	536	630	749	1020
Polyethylene terephthalate	max. g PET	167	219	277	346	427	517	607	723	984
Polyethylene	max. g PE-LD	106	139	176	219	271	328	385	458	624
	max. g PE-HD	110	143	181	227	280	339	398	473	644
Polypropylene	max. g PP	112	146	185	232	286	346	406	484	658
Fluoropolymerides	max. g FEP, PFA, PCTFE <sup>1)</sup>	225	294	372	465	574	695	816	971	1322
	max. g ETFE	196	256	324	408	504	609	716	852	1160
Polyvinyl chloride	max. g PVC-U	170	222	281	351	434	525	616	734	998
	max. g PVC-P <sup>1)</sup>	157	205	260	324	401	485	569	678	922

1) average value

**ARBURG GmbH + Co KG**  
 Arthur-Hehl-Strasse  
 72290 Lossburg  
 Tel.: +49 7446 33-0  
[www.arburg.com](http://www.arburg.com)  
[contact@arburg.com](mailto:contact@arburg.com)