

## **ALLROUNDER 420 C**

### **GOLDEN EDITION**

Distance between tie bars: 420 x 420 mm

Clamping force: 1000 kN

Injection unit (acc. to EUROMAP): 290

**ARBURG**

# MACHINE DIMENSIONS | 420 C GOLDEN EDITION

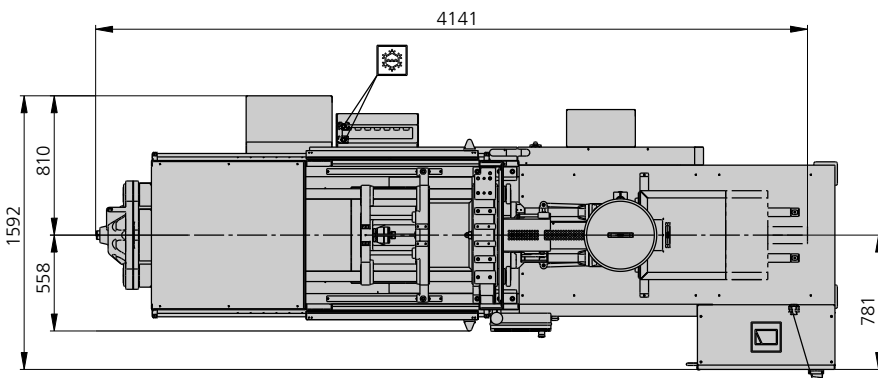
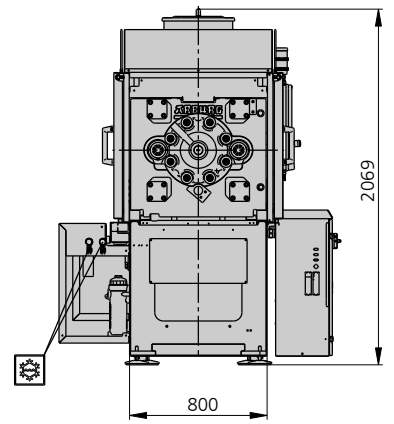
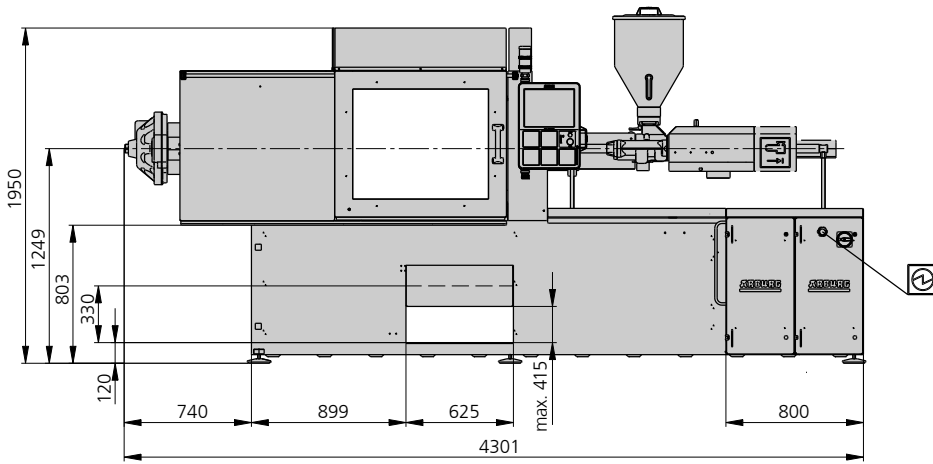

Electrical connection



Cooling water connection

# TECHNICAL DATA | 420 C GOLDEN EDITION

Clamping unit		420 C GOLDEN EDITION	
with clamping force	max. kN	1000	
Opening force   stroke	max. kN   mm	250   500	
Mould height, fixed   variable	min. mm	250   ---	
Platen daylight fixed   variable	max. mm	750   ---	
Distance between tie bars (w x h)	mm	420 x 420	
Mould mounting platens (w x h)	max. mm	570 x 570	
Weight of movable mould half	max. kg	600	
Ejector force   stroke	max. kN   mm	40   175	
Dry cycle time EUROMAP <sup>2</sup>	min. s - mm	1,8 - 294	

Injection unit		290		
with screw diameter	mm	30	35	40
Effective screw length	L/D	23,3	20	17,5
Screw stroke	max. mm	150		
Calculated stroke volume	max. cm <sup>3</sup>	106	144	188
Shot weight	max. g PS	97	132	172
Material throughput	max. kg/h PS	17	20,5	24,5
	max. kg/h PA6.6	8,5	10,5	12,5
Injection pressure	max. bar	2500	2000	1530
Holding pressure	max. bar	2500	2000	1530
Injection flow <sup>2</sup>	max. cm <sup>3</sup> /s	102	140	182
Screw circumferential speed <sup>2</sup>	max. m/min	46	54	62
Screw torque	max. Nm	320	380	430
Nozzle contact force   retraction stroke	max. kN   mm	60   240		
Heating capacity   zones	kW	6,4   5		
Feed hopper	l	50		

Drive and connection		2 pumps	
with injection unit		290	
Net weight of machine	kg	3650	
Sound press. level   Insecurity <sup>4</sup>	dB(A)	68   3	
Oil filling	l	235	
Drive power <sup>2</sup>	max. kW	15	
Electrical connection <sup>3</sup>	kW	24	
	Total	80	
	Machine	---	
	Heating	---	
Cooling water connection	max. °C	30	
	min. Δp bar	1,5   DN 25	

**Machine type**  
with EUROMAP size designation <sup>1</sup>  
420 C GOLDEN EDITION 1000-290

All specifications relate to the basic machine version. Deviations are possible depending on variants, process settings and material type. Depending on the drive, certain combinations, e.g. max. injection pressure and max. injection flow may be mutually exclusive.

- 1) Clamping force (kN) - size of injection unit = max. stroke volume (cm<sup>3</sup>) x max. injection pressure (kbar)
  - 2) Specifications depend on the drive variant / drive configuration.
  - 3) Specifications relate to 400 V/50 Hz.
  - 4) Detailed info in the operating instr.
- [ ] Specifications apply to alternative equipment.

# MOULD INSTALLATION DIMENSIONS | 420 C GOLDEN EDITION

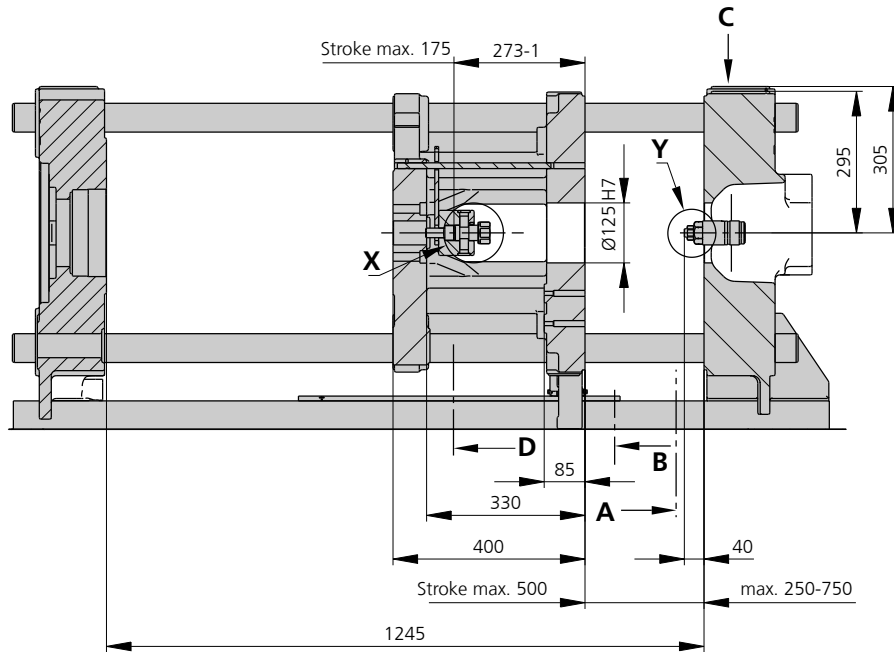

**Ejector bolt | X**

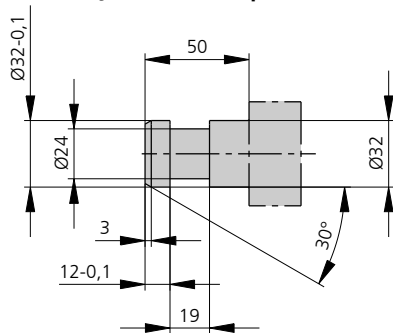

**Bore in mould (if required) | Y**

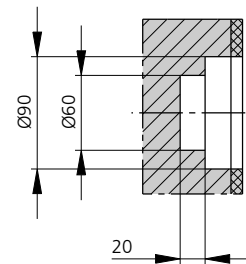

**Robotic system mounting | C**

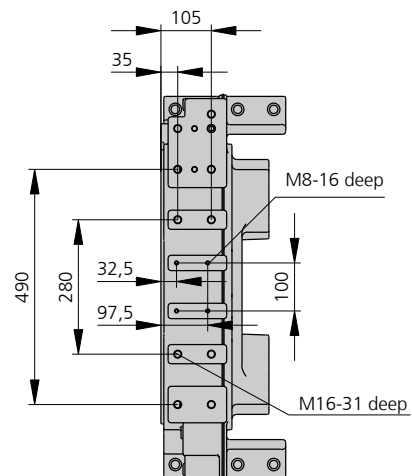

**D view**

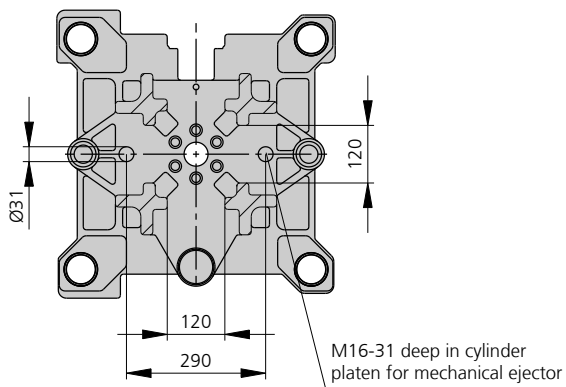

# MOULD INSTALLATION DIMENSIONS | 420 C GOLDEN EDITION

## Fixed mould mounting platen | A

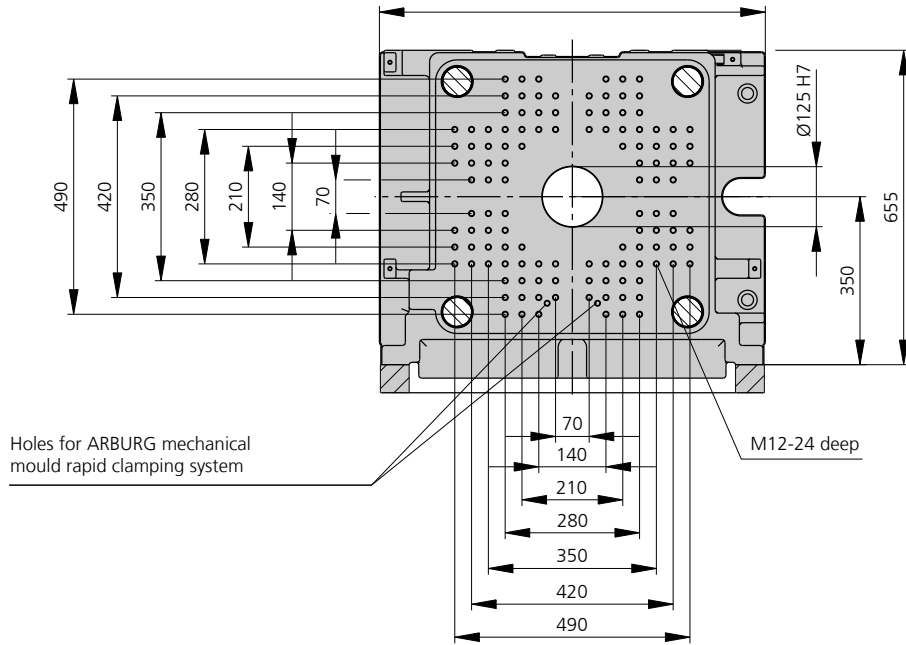

## Moving mould mounting platen | B

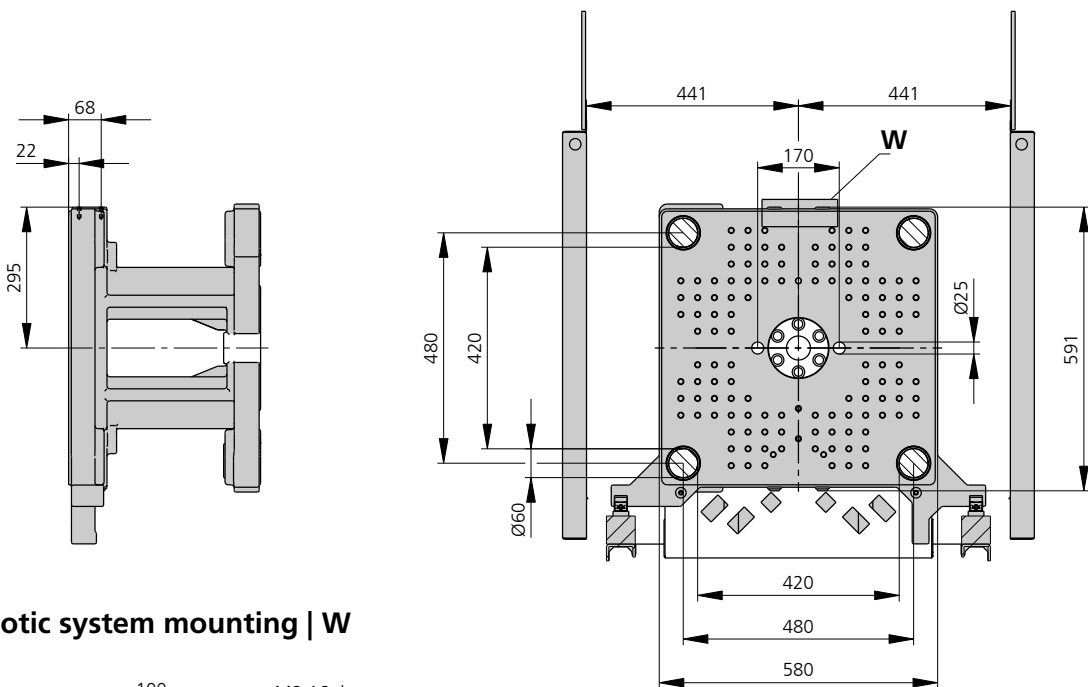

## Robotic system mounting | W

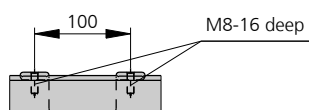

# SHOT WEIGHTS | 420 C GOLDEN EDITION

## Theoretical shot weights for the most important injection moulding materials

Injection units according to EUROMAP		290				
Screw diameter	mm	30	35	40		
Polystyrene	max. g PS	97	132	172		
Styrene heteropolymerizates	max. g SB	95	129	168		
	max. g SAN, ABS <sup>1)</sup>	93	126	165		
Cellulose acetate	max. g CA <sup>1)</sup>	109	148	194		
Celluloseacetobutyrate	max. g CAB <sup>1)</sup>	101	138	180		
Polymethyl methacrylate	max. g PMMA	100	136	178		
Polyphenylene ether, mod.	max. g PPE	90	122	160		
Polycarbonate	max. g PC	102	139	181		
Polysulphone	max. g PSU	105	143	187		
Polyamides	max. g PA 6.6   PA 6 <sup>1)</sup>	96	131	171		
	max. g PA 6.10   PA 11 <sup>1)</sup>	90	122	160		
Polyoximethylene (Polyacetal)	max. g POM	120	163	213		
Polyethylene terephthalate	max. g PET	115	157	205		
Polyethylene	max. g PE-LD	73	100	130		
	max. g PE-HD	76	103	134		
Polypropylene	max. g PP	77	105	137		
Fluoropolymerides	max. g FEP, PFA, PCTFE <sup>1)</sup>	155	211	276		
	max. g ETFE	136	185	242		
Polyvinyl chloride	max. g PVC-U	117	159	208		
	max. g PVC-P <sup>1)</sup>	108	147	192		

1) average value

### ARBURG GmbH + Co KG

Arthur-Hehl-Strasse  
72290 Lossburg  
Tel.: +49 7446 33-0  
www.arburg.com  
contact@arburg.com