

ALLROUNDER 275 V

Vertical free-space system

Clamping force: 250 kN

Injection unit (according to EUROMAP): 70, 100

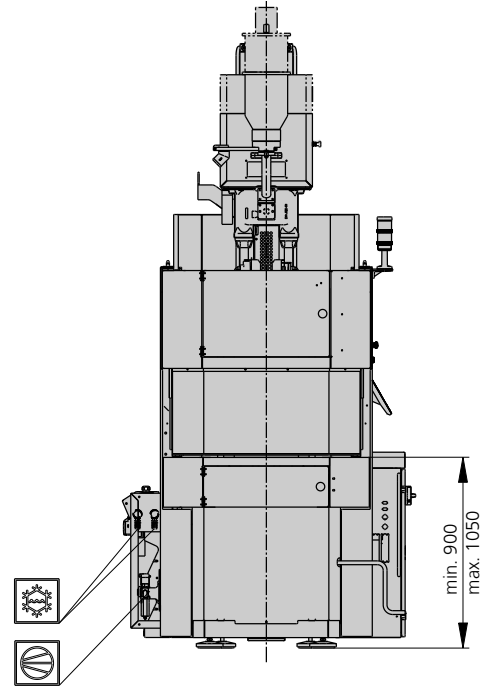
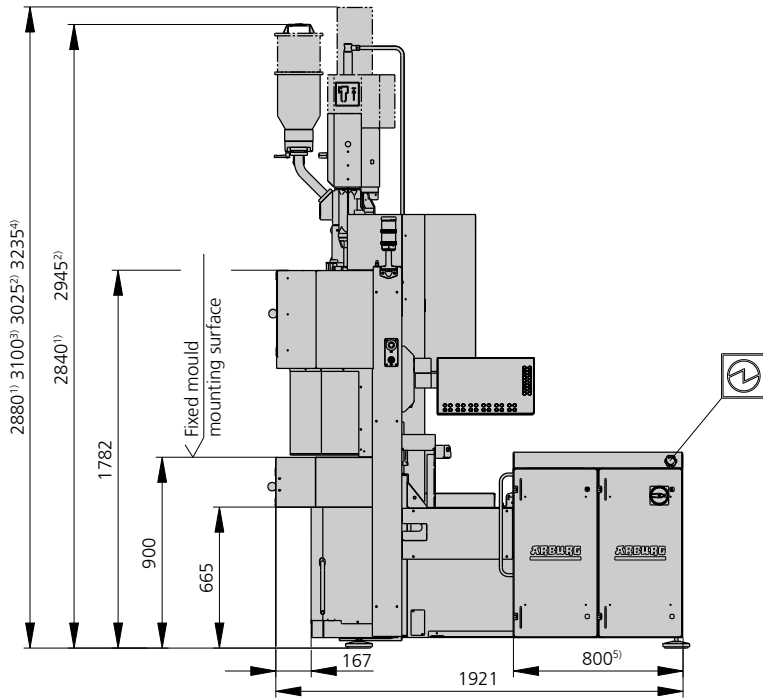

ARBURG

INSTALLATION DIMENSIONS STANDARD | 275 V

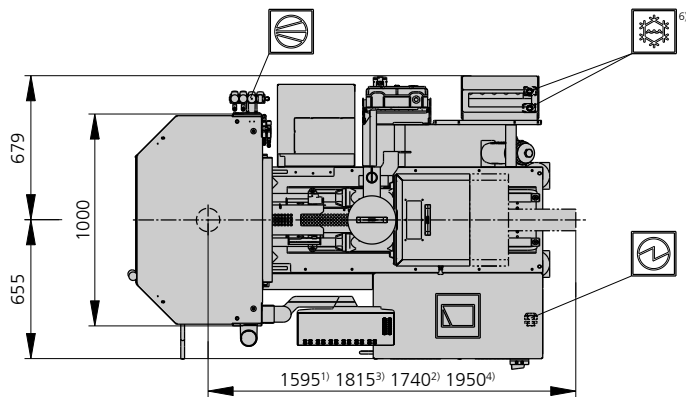
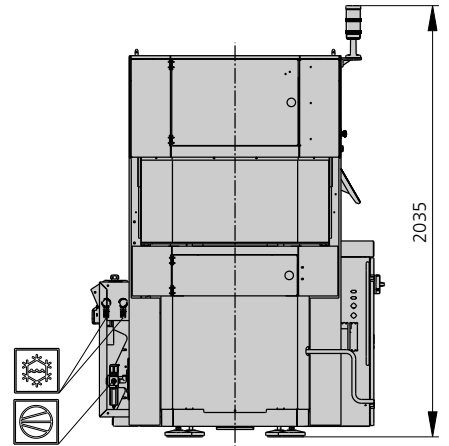
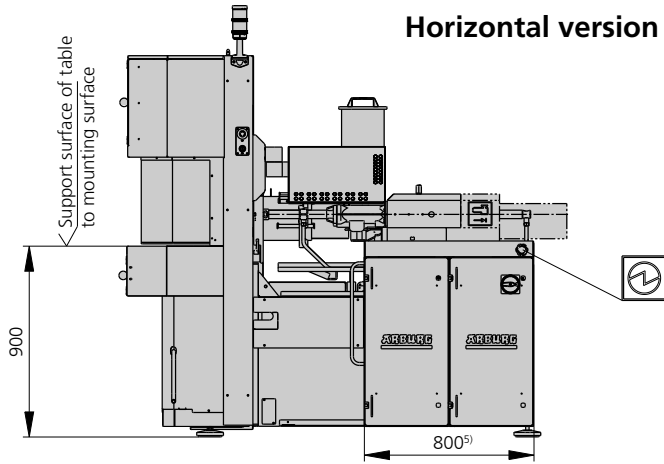

Horizontal version



-  Electrical connection
-  Cooling water connection
-  Pneumatic connection

- 1) Injection unit 70
- 2) Injection unit 100
- 3) Injection unit 70 AED
- 4) Injection unit 100 AED
- 5) The control cabinet length and position of the electrical connection can vary due to optional equipment
- 6) Position of cooling water connections can vary due to optional equipment

TECHNICAL DATA | 275 V

Clamping unit		275 V		
with clamping force	max. kN	250		
Version		Standard	Rotary table	Shuttle table
Opening force stroke	max. kN mm	100 225	100 225	100 225
Mould height, fixed variable	min.-max. mm	--- 150-250	--- 127-227	--- 122-222
Platen daylight fixed variable	max. mm	--- 375-475	--- 352-452	--- 347-447
Table diameter	mm	---	750	---
Shuttle table stroke	mm	---	---	500
Angle of rotation, left/right		---	180°	---
	min. s	---	1,7	1,2
Weight on rotary/shuttle table	max. kg	---	120	120
Weight of movable mould half	max. kg	110	110	110
Ejector force stroke	max. kN mm	30 60	16 40	16 40
Dry cycle time EUROMAP ²	min. s - mm	4,8 - 192	4,8 - 192	4,8 - 192

Injection unit		70			100		
with screw diameter	mm	18	22	25	20	25	30
Effective screw length	L/D	24,5	20	17,5	25	20	16,7
Screw stroke	max. mm	90			100		
Calculated stroke volume	max. cm ³	23	34	44	31	49	71
Shot weight	max. g PS	21	31	40	29	45	65
Material throughput	max. kg/h PS	4,1	5,5	6,5	5,5	8	9,5
	max. kg/h PA6.6	2,1	2,8	3,3	2,8	4	4,9
Injection pressure	max. bar	2500	2000	1550	2500	2000	1390
Holding pressure	max. bar	2500	2000	1550	2500	2000	1390
Injection flow ²	max. cm ³ /s	42	62	80	40	62	90
Screw circumferential speed ²	max. m/min	24	30	34	17	22	26
Screw torque	max. Nm	90	110	120	120	150	180
Nozzle contact force retraction stroke	max. kN mm	50 150			50 180		
Heating capacity zones	kW	4,2 4			6,7 5		
Feed hopper	l	8			8		

Drive and connection		Standard		Rotary table		Shuttle table	
with injection unit		70	100	70	100	70	100
Net weight of machine	kg	1745	1765	2215	2235	2120	2140
Sound press. level Insecurity ⁴	dB(A)	67 3		67 3		67 3	
Oil filling	l	80		80		80	
Drive power ²	max. kW	7,5		7,5		7,5	
Electrical connection ³	kW	14	15	14	17,5	14	15
	Total	A	50	50		50	50
	Machine	A	---	---		---	---
	Heating	A	---	---		---	---
Cooling water connection	max. °C	25		25		25	
	min. Δp bar	1,5 DN 25		1,5 DN 25		1,5 DN 25	

Machine type

with EUROMAP size designation ¹

275 V 250-70 | 100

Upon request: other machine types and mould installation heights, screws, drive powers, etc.

All specifications relate to the basic machine version. Deviations are possible depending on variants, process settings and material type. Depending on the drive, certain combinations, e.g. max. injection pressure and max. injection flow may be mutually exclusive.

1) Clamping force (kN) - large injection unit = max. stroke volume (cm³) x max. injection pressure (kbar)

2) Specifications depend on the drive variant / drive configuration.

3) Specifications relate to 400 V/50 Hz.

4) Detailed info in the operating instr.

[] Specifications apply to alternative equipment.

MOULD INSTALLATION DIMENSIONS STANDARD | 275 V

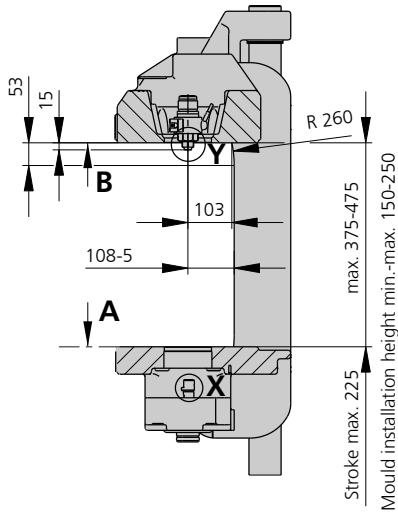

Ejector bolt | X

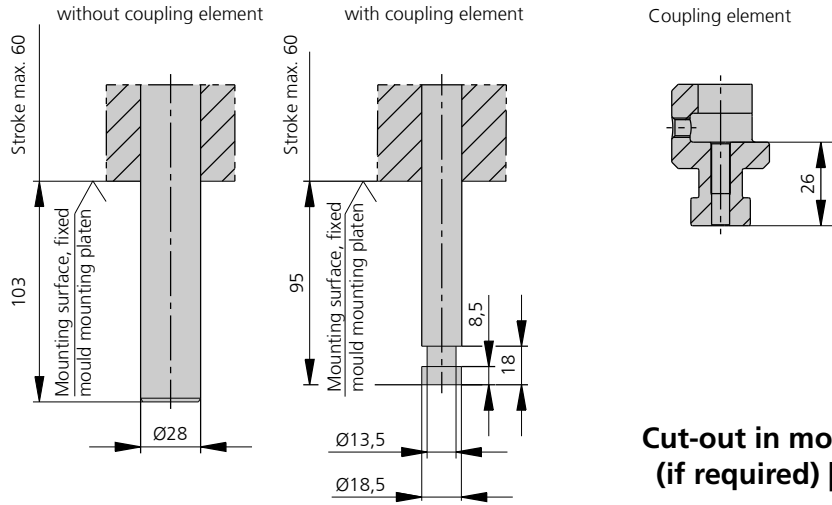

Cut-out in mould (if required) | Y

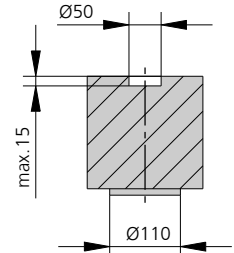

Horizontal version

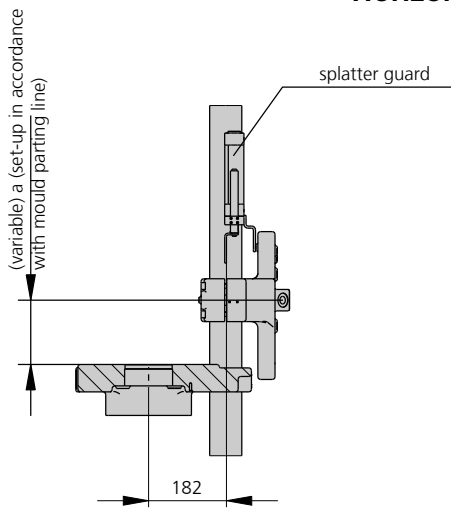

Bore in mould (if required)

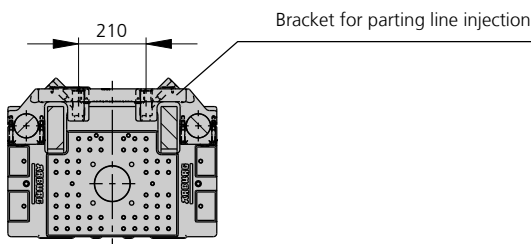
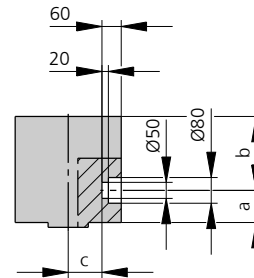

	Injection positions		with hydraulic nozzle	
	for Injection unit			
	70	100	70	100
a min.	80		80	
a max.	150		150	
b min.	50		50	
c min.	73		39	53

ROTARY TABLE INSTALLATION DIMENSIONS | 275 V

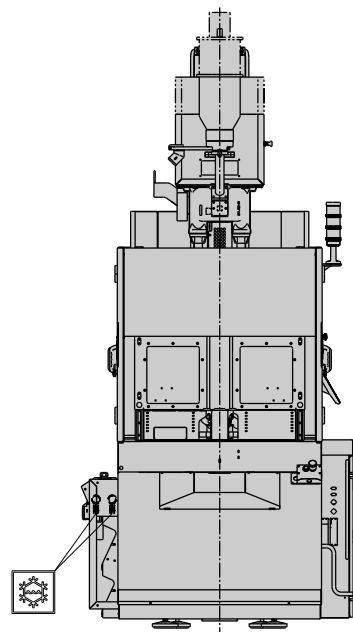
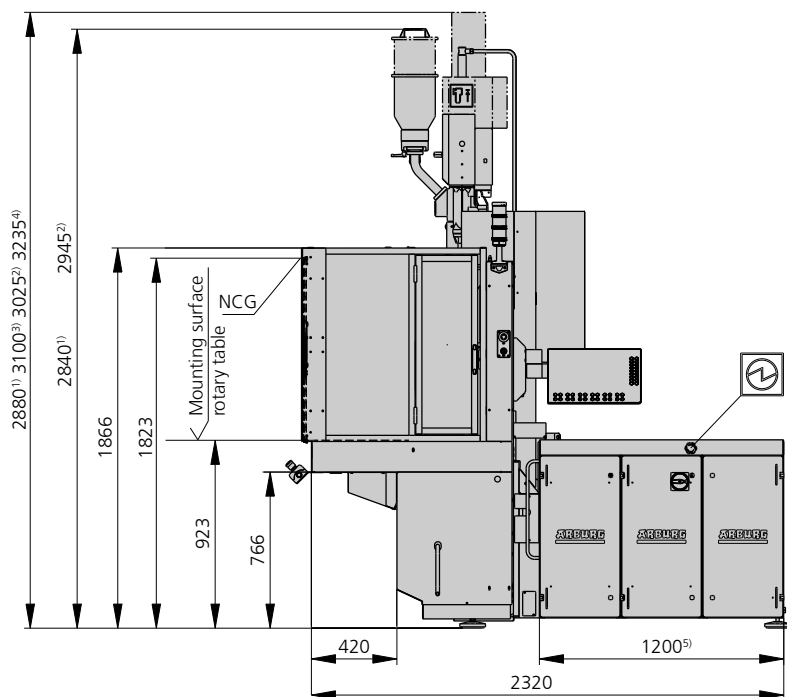

Horizontal version

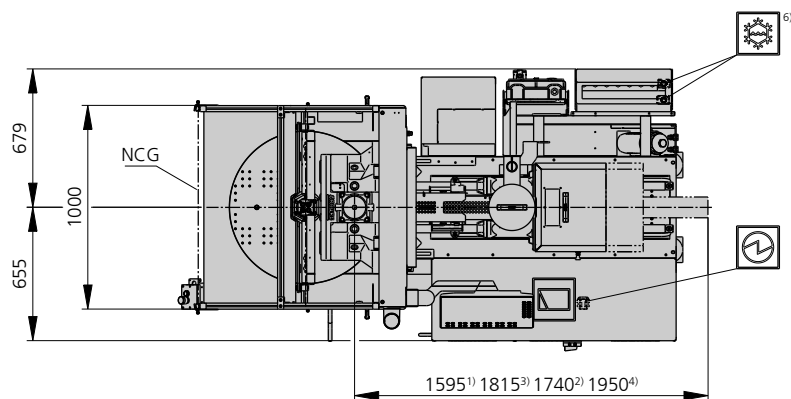
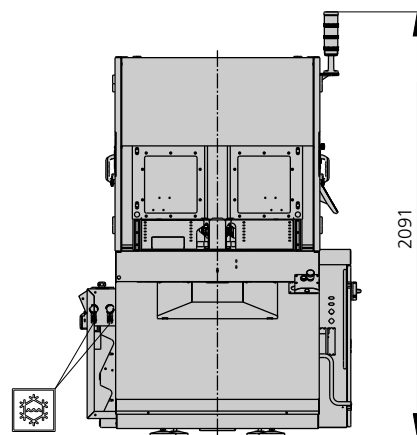
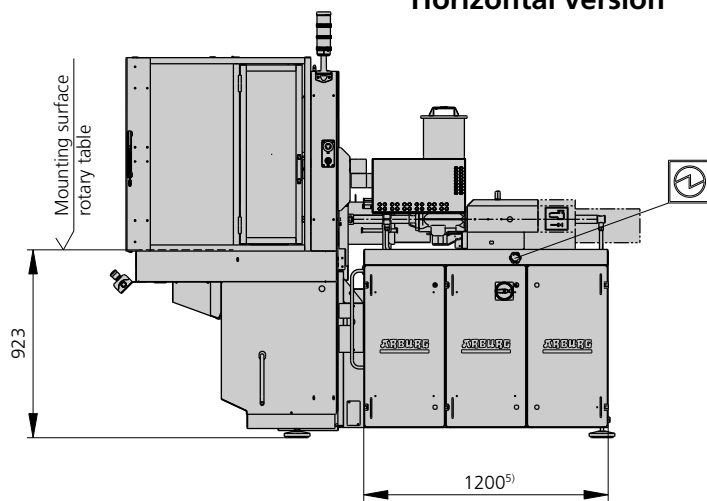

 Electrical connection

 Cooling water connection

- 1) Injection unit 70
- 2) Injection unit 100
- 3) Injection unit 70 AED
- 4) Injection unit 100 AED
- 5) The control cabinet length and position of the electrical connection can vary due to optional equipment
- 6) Position of cooling water connections can vary due to optional equipment

NCG - Non-contacting guard (photoelectric safety barrier)

MOULD INSTALLATION DIMENSIONS FOR ROTARY TABLE | 275 V

Ejector bolt (for gentle ejection)

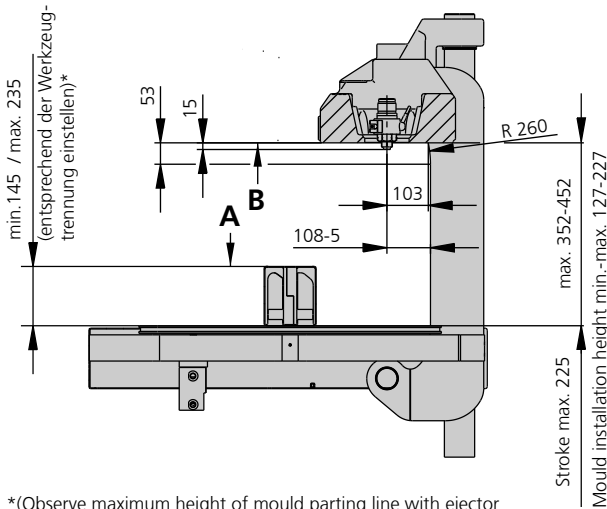

*(Observe maximum height of mould parting line with ejector stroke and height of sprue in case of vertical injection unit)

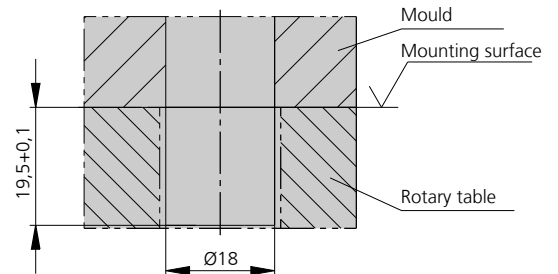

Mould mounting platen rotary table | A

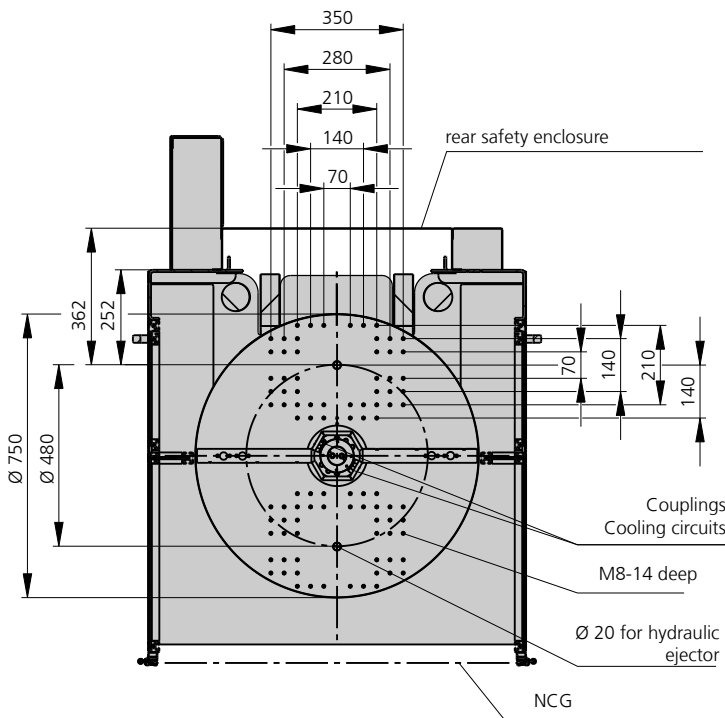

Useable mounting surface

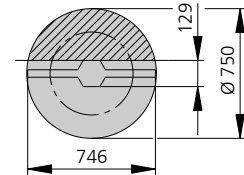

Moving mould mounting platen | B

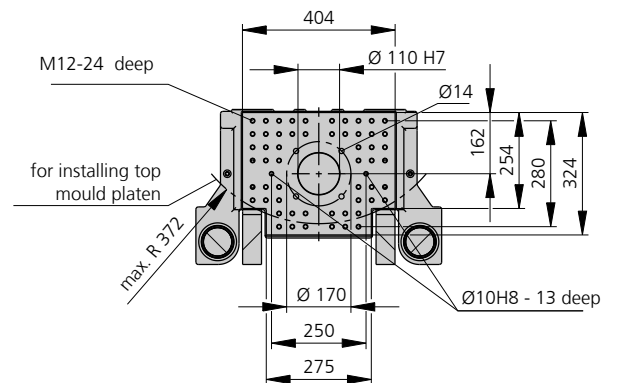

MOULD INSTALLATION DIMENSIONS FOR ROTARY TABLE | 275 V

Horizontal version

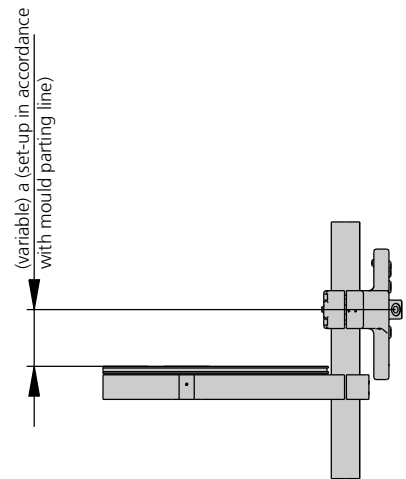
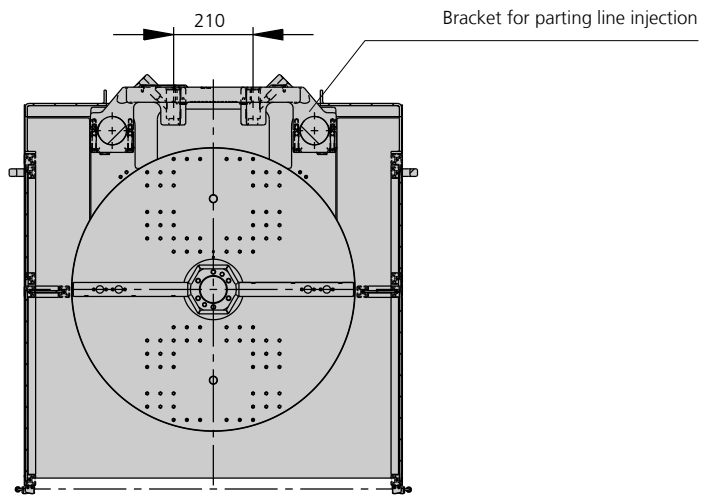

Bore in mould (if required)

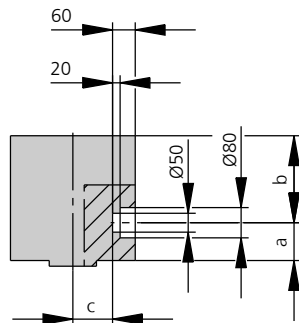



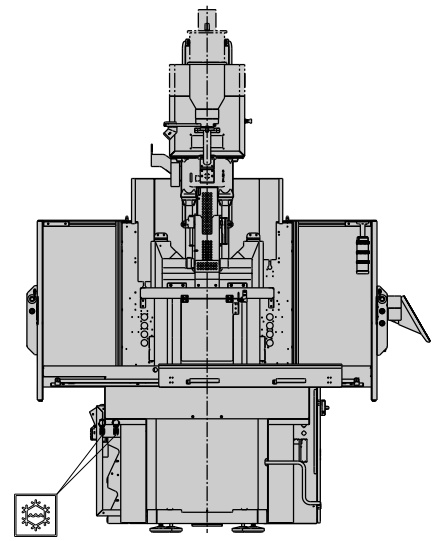
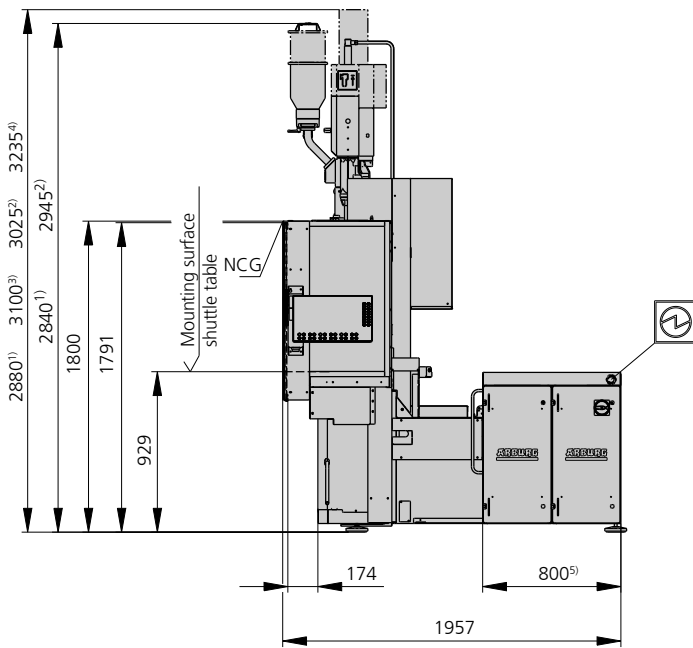

	Injection positions		with hydraulic nozzle	
	for Injection unit			
	70	100	70	100
a min.	80		80	
a max.	150		150	
b min.	50		50	
c min.	73		39	53

OVERALL DIMENSIONS - SHUTTLE TABLE | 275 V

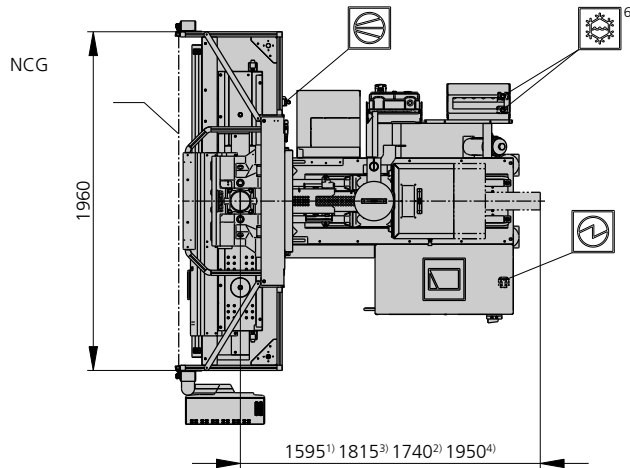
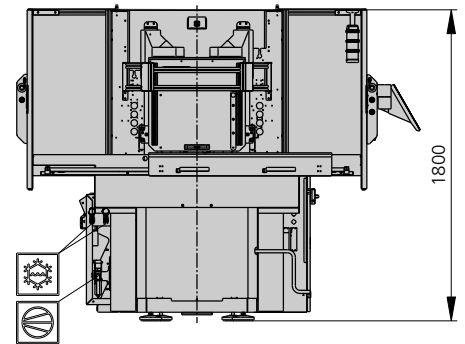
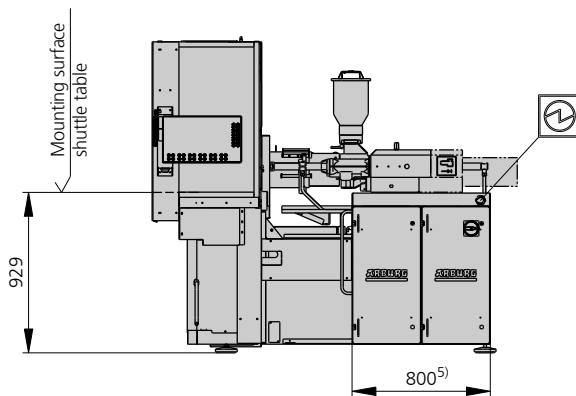

Horizontal version



-  Electrical connection
-  Cooling water connection
-  Pneumatic connection

- 1) Injection unit 70
- 2) Injection unit 100
- 3) Injection unit 70 AED
- 4) Injection unit 100 AED
- 5) The control cabinet length and position of the electrical connection can vary due to optional equipment
- 6) Position of cooling water connections can vary due to optional equipment

NCG - Non-contacting guard (photoelectric safety barrier)

MOULD INSTALLATION DIMENSIONS - SHUTTLE TABLE | 275 V

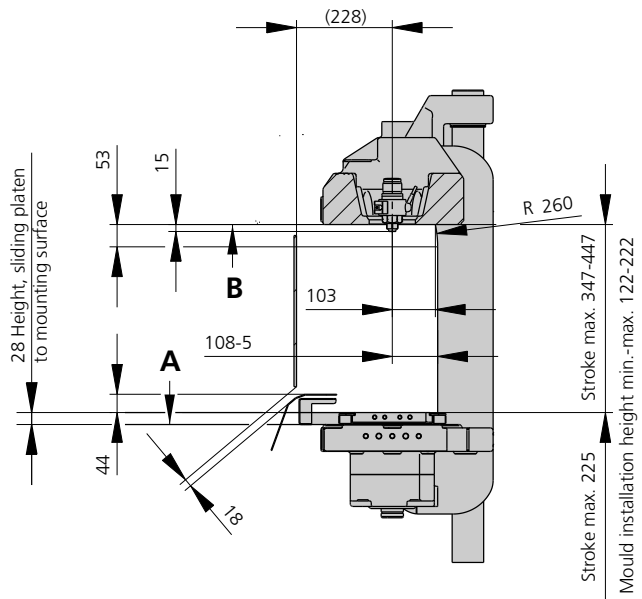

Ejector bolt (for gentle ejection)

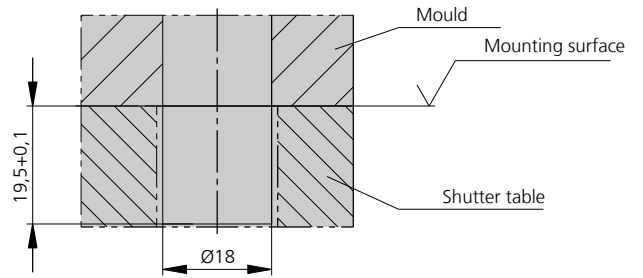

Mould mounting platen for shuttle table | A

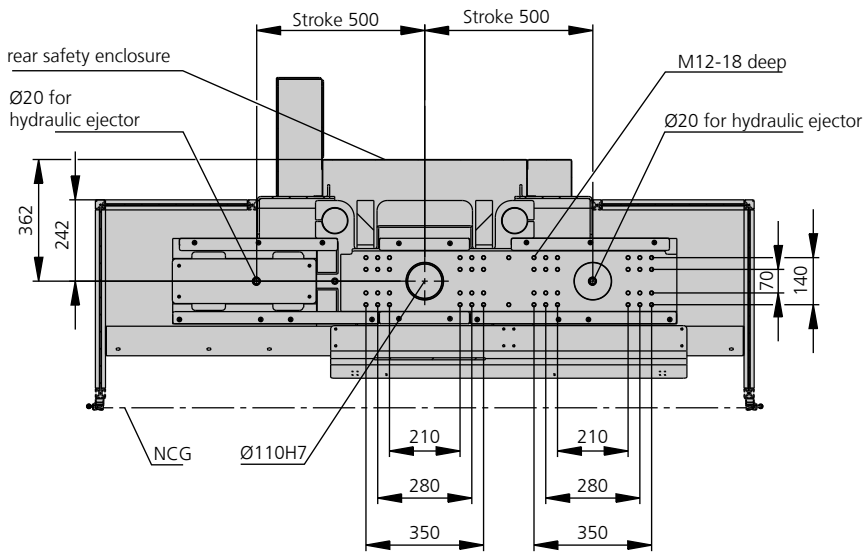

Useable mounting surface

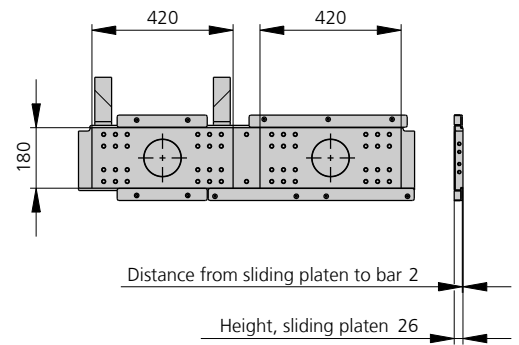

Moving mould mounting platen | B

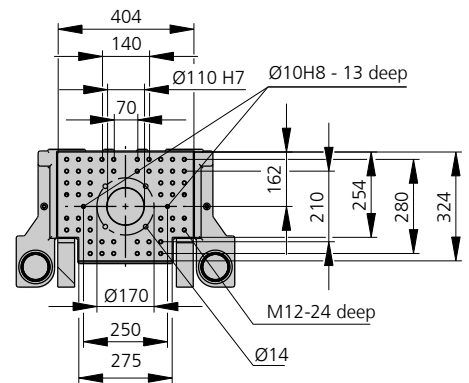

MOULD INSTALLATION DIMENSIONS - SHUTTLE TABLE | 275 V

Horizontal version

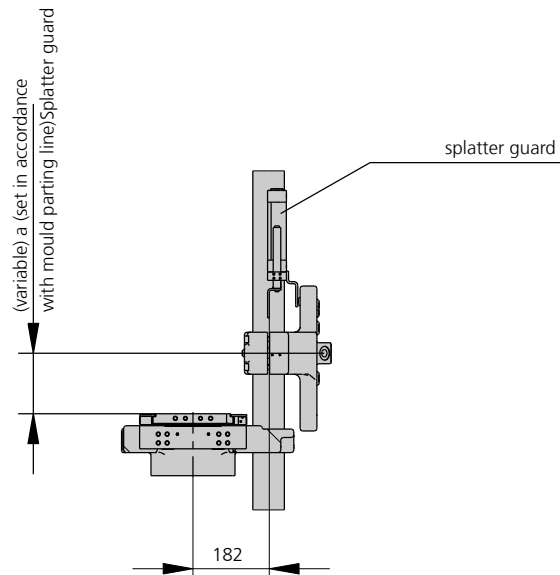
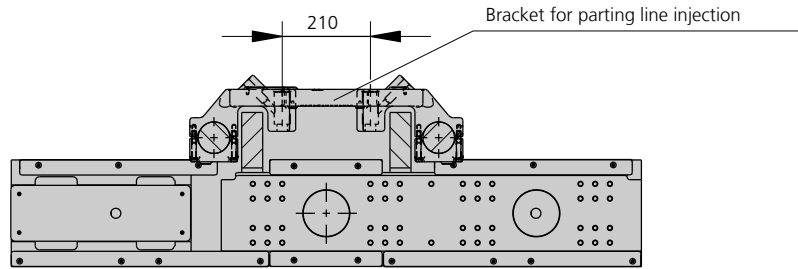

Bore in mould (if required)

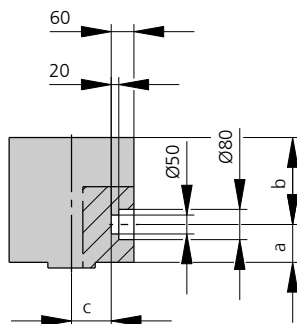

	Injection positions		with hydraulic nozzle	
	for Injection unit			
	70	100	70	100
a min.	80		80	
a max.	150		150	
b min.	50		50	
c min.	73		39	53

SHOT WEIGHTS | 275 V

Theoretical shot weights for the most important injection moulding materials

Injection units according to EUROMAP		70			100		
Screw diameter	mm	18	22	25	20	25	30
Polystyrene	max. g PS	21	31	40	29	45	65
Styrene heteropolymerizates	max. g SB	20	31	39	28	44	63
	max. g SAN, ABS ¹⁾	20	30	39	27	43	62
Cellulose acetate	max. g CA ¹⁾	24	35	45	32	50	73
Celluloseacetobutyrate	max. g CAB ¹⁾	22	33	42	30	47	68
Polymethyl methacrylate	max. g PMMA	22	32	42	30	46	67
Polyphenylene ether, mod.	max. g PPE	19	29	37	27	42	60
Polycarbonate	max. g PC	22	33	42	30	47	68
Polysulphone	max. g PSU	23	34	44	31	49	70
Polyamides	max. g PA 6.6 PA 6 ¹⁾	21	31	40	28	44	64
	max. g PA 6.10 PA 11 ¹⁾	19	29	37	26	41	60
Polyoximethylene (Polyacetal)	max. g POM	26	39	50	35	55	80
Polyethylene terephthalate	max. g PET	25	37	48	34	53	77
Polyethylene	max. g PE-LD	16	24	30	22	34	49
	max. g PE-HD	16	24	31	22	35	50
Polypropylene	max. g PP	17	25	32	23	36	51
Fluoropolymerides	max. g FEP, PFA, PCTFE ¹⁾	33	50	65	46	72	103
	max. g ETFE	29	44	57	40	63	91
Polyvinyl chloride	max. g PVC-U	25	38	49	35	54	78
	max. g PVC-P ¹⁾	23	35	45	32	50	72

1) average value

ARBURG GmbH + Co KG
 Arthur-Hehl-Strasse
 72290 Lossburg
 Tel.: +49 7446 33-0
 www.arburg.com
 contact@arburg.com