

ALLROUNDER 275 V

Technical data

Vertical free-space system

Clamping force: 250 kN

Injection unit (acc. to EUROMAP): 70, 100

ARBURG

Vertikal-
version

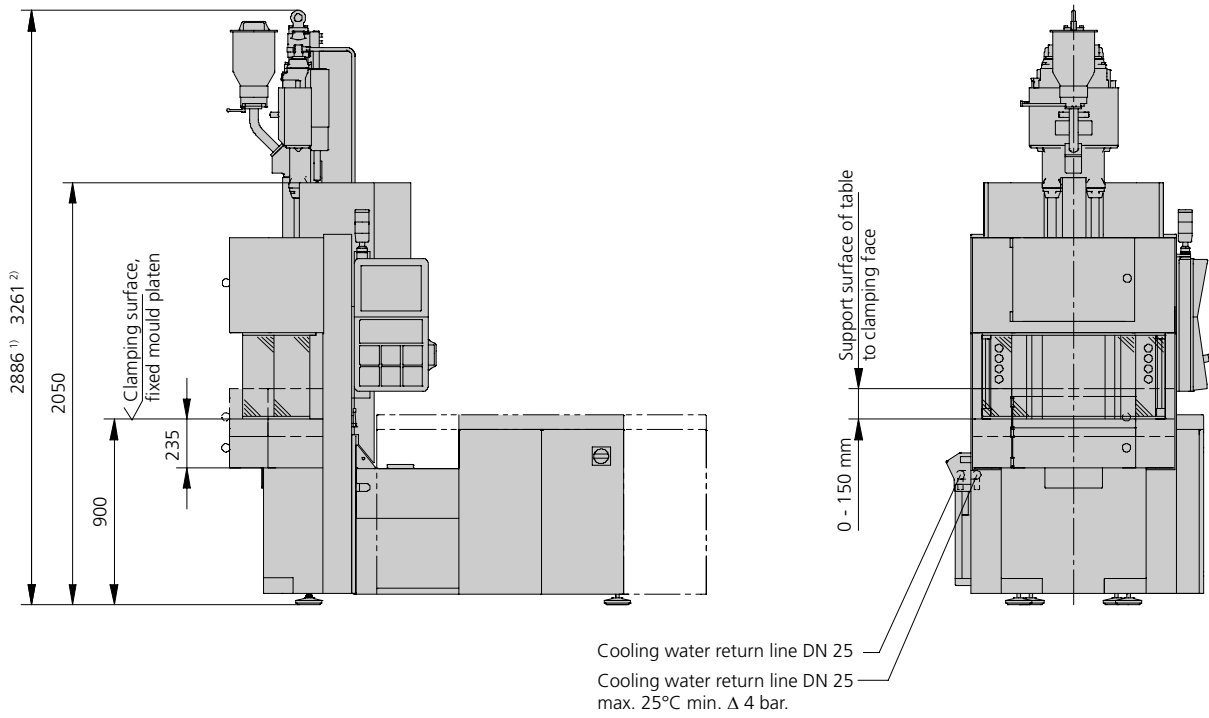

Horizontal version

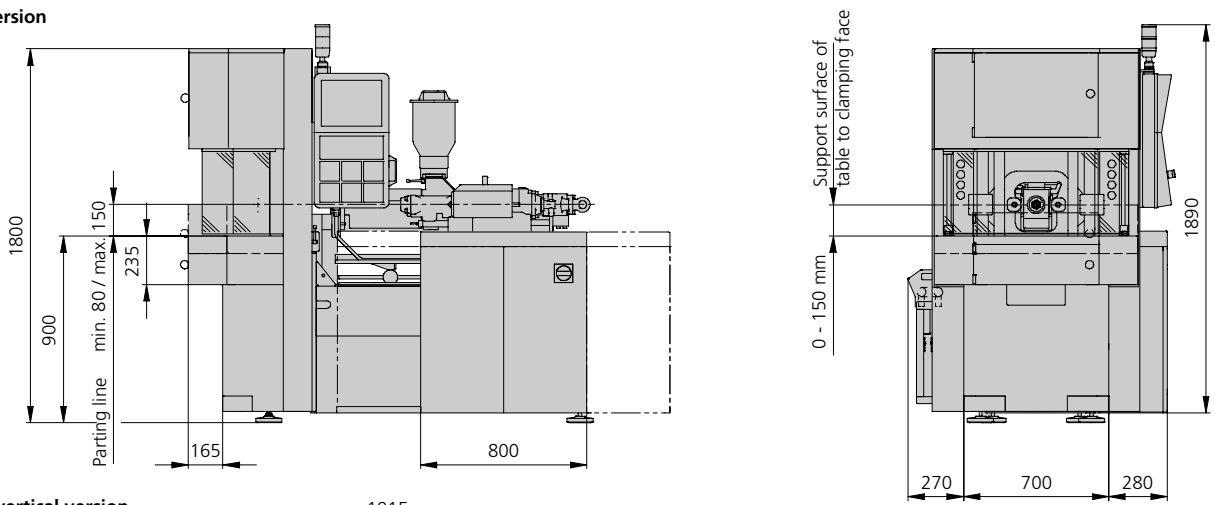

Horizontal / vertical version

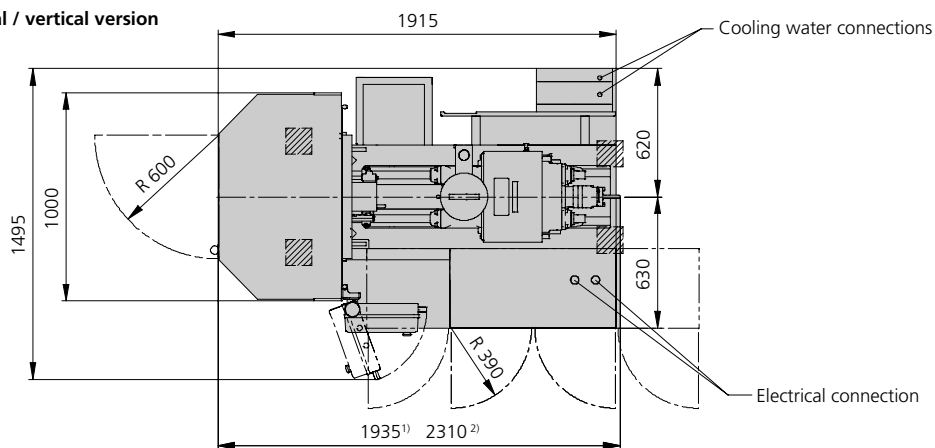

- 1) Dimensions for injection unit 70
- 2) Dimensions for injection unit 100
- 3) Additional control cabinet dependent on installed power consumption or options

Machine model		275 V	275 V
EUROMAP size indication ¹⁾		250-70	250-100
Clamping unit			
Clamping force	max. kN	250	250
Closing force	max. kN	30	30
Opening force	max. kN	60	60
Opening stroke	max. mm	225	225
Mould height	min. mm	150-250	150-250
Daylight	max. mm	375-475	375-475
Weight of mov. mould half ⁶⁾	max. kg	110	110
Ejector force	max. kN	20	20
Ejector stroke	max. mm	60	60
Hydraulics, drive, general			
Drive power of the hydraulic pump	kW	7,5	7,5
Dry cycle time for opening stroke ⁵⁾	s-mm	---	---
Total connected load ²⁾	kW	13,9	15
Colour: plastic coated, structure light gray / mint green / canary yellow			
Control cabinet			
Safety standard according to		DIN EN 60204	DIN EN 60204
Socket combination (1 single phase, 1 three-phase)		1 x 16 A	1 x 16 A
Injection unit		70	100
Screw diameter	mm	18 / 22 / 25	20 / 25 / 30
Effective screw length	L/D	24,5 / 20 / 17,5	25 / 20 / 16,7
Screw stroke	max. mm	90	100
Calculated injection volume	max. cm ³	23 / 34 / 44	31 / 49 / 71
Shot weights	max. g PS	21 / 31 / 40	29 / 45 / 65
Material throughput ⁴⁾	max. kg/h PS	4,1 / 5,5 / 6,5	5,5 / 8 / 9,5
	max. kg/h PA 6.6	2,1 / 2,8 / 3,3	2,8 / 4 / 4,9
Injection pressure ³⁾	max. bar	2500 / 2000 / 1550	2500 / 2000 / 1390
Injection flow ³⁾	max. cm ³ /s	42 / 62 / 80	40 / 62 / 90
Back pressure positive/negative	max. bar	350 / 200	350 / 200
Circumferential screw speed	max. m/min	24 / 30 / 34	17 / 22 / 26
Screw torque	max. Nm	90 / 110 / 120	120 / 150 / 180
Nozzle contact force	max. kN	50	50
Nozzle retraction stroke	max. mm	150	180
Installed cylinder heating power / heating zones	kW	3,75 / 3	4,3 / 4
Installed nozzle heating power	kW	0,3	0,6
Material hopper capacity	l	8	8
Machine dimensions and weights of the basic machine			
Oil capacity	l	80	80
Net weight	kg	1730	1750
Electrical connection ²⁾	A	50	50

1) 1st figure: clamping force (kN), 2nd figure: max. dosage volume (cm³) x max. injection pressure (kbar)

2) Values refer to 400 V/50 Hz. The load is symmetrically distributed on three phases (observe phase loading when installing new equipment).

3) A combination of max. injection pressure and max injection flow (max. injection capacity) can be mutually exclusive, depending on the equipment-related motor output.

4) Deviations are possible depending upon process settings and material type

5) According to EUROMAP for basic machine.

6) Restriction only applies to vertical injection units

The shown specifications reflect the state at the time of printing. In the interest of a continuous development of our products, we reserve the right to modify specifications.

Control system and control cabinet

- SELOGICA direct (touchscreen user interface for direct data access)
- Available in different language versions
- Language change
- Cycle sequence programming with symbols
- Cycle step display in sequence diagram
- Cycle time diagram
- Swivelling monitor unit, central on the operator's side, with colour monitor
- Process graphics for injection speed, screw stroke and injection pressure
- Quality assurance program with fault evaluation and monitoring chart
- Optimisation and user help, follow-on functions at cycle end, for freely programmable parameter pages, selectable units
- Modular control cabinet design with self-recognition of plug in circuit board system
- Operating modes:
 - Set up
 - Freely programmed test run
 - Reconfiguration
 - Automatic purging and dosing
- Equipment for switch-over to holding pressure via injection pressure, material pressure with different pressure transducers, or via external switch signal
- Data record management via Compact Flash
- Visual warning signal (warning lamp)
- Visual / audible warning signal (flashing light / siren)
- Printer interface for hard copy, data record and quality protocol

- Interfaces for: PC keyboard, plotter, robotic system in accordance with EUROMAP 67, host processor, AQC, ALLROUNDER@web, colouring unit, LSR dosing system, INJESTER, container change, THERMOLIFT, hot runner control unit and temperature control units for moulds and cylinder
- Socket combination 1 CEE, 1 Schuko 230 V
- Socket combination 1 CEE, 1 Schuko or 3 CEE, 3 Schuko 230 V with external supply line
- 1 additional heating regulation circuit for the nozzle
- Electric heating regulation circuits for moulds (adaptive) (3, 6, 9, 12); mould heating fused at 10 A
- Fuses for mould heating 16 A
- 4 or 8 freely programmable inputs / outputs
- Core pull programs in many versions integrated in the SELOGICA control system
- Special processes such as injection coining and mould venting
- Monitoring: freely-programmable position monitoring

Machine base and hydraulic system

- Free standing machine base on anti-vibration pads
- Guarding, down stroking, adjustable on the parting line
- Space for peripheral devices within floor space
- The hydraulic system operates with an energy-saving variable displacement pump and a servo valve for pressure and speed regulation
- Monitoring of oil level, oil temperature and oil filter contamination
- Fine mesh oil filter in the return line
- Mechanical regulation of hydraulic oil temperature

- Electronic regulation of hydraulic oil temperature. Display and monitoring via screen
- Hydraulic oil preheating program to reduce start-up time
- Manually adjustable, machine-related cooling water circuits with 2 free mould connections
- 4 free cooling water circuits, manually adjustable
- Programmable, machine and mould-related cooling water circuits
- 1 or 2 central shut-off valves for cooling water (supply and/or return)

Clamping unit

- Clamping unit with free-space system
- Centrally applied fully hydraulic clamping system. Fixed mould platen positioned at bottom
- Mould height adjustment for achieving different mould installation heights
- Movement profiles for the mould clamping unit are programmable and regulated. They are serially driven using energy-saving one-circuit pump technology (Technology stage 1)
- Closing and opening profiles are programmable in 2 stages
- Intermediate stop possible in closing and opening movements
- Regulated hydraulic mould protection with monitoring of mould protection time. Follow-up functions: open or stop after 1 or 2 activations of mould protection
- Extended mould protection (e.g. for spring moulds). Freely-programmable start and end
- Automatic ramp function during switch-over to a lower speed and for stop of driven movements
- Hydraulic ejector integrated into the clamping system
- Hydraulic ejector: forces and speeds, multiple stroke (up to 10) and ejector advanced at end of cycle are programmable

- Mould monitoring via ejector platen safety switch
- Hydraulic core pulls with rapid connect couplings, connections to hydraulic manifold
- Hydraulic core pull movement profiles programmable and regulated
- Core hold on pressure manually adjustable
- Pressure hold programmable
- Power-operated safety gate
- Mould blow unit with pressure relief valve
- Mechanical mould closing protection
- Rotary table with servo-electric rotary drive

Injection unit

- Modular injection unit as complete assembly group
- Vertical injection unit
- Device for horizontal injection into the parting line
- Lifting device for parting line injection unit
- Plasticising module with universal screw, central coupling and adaptive temperature regulation, available in different diameters
- Thermoplastic cylinder with universal screw in wear resistant execution
- Thermoplastic cylinder in very high wear resistant execution
- Plasticising module for processing thermoset, elastomer and silicone materials
- Thermoplast screws for special applications, e.g. self-colouring (mixing section), PVC (shear-sensitive), POM, PA (semi-crystalline)
- Programmable nozzle speeds (advance 2, retract 1 stage) and advance and retract delay
- Monitored nozzle contact
- Continuous nozzle contact during the complete cycle
- Programmable nozzle contact force

- Regulated nozzle contact force
- Regulated injection speed profile, 2 steps programmable with injection delay
- Position-regulated screw (forced movement of injection axis)
- Injection process control with external sensor
- Measurement, display and monitoring of the injection time, switch-over volume and switch-over pressure
- Switch-over to holding pressure as a volume or time-dependent function
- Material cushion monitoring
- Holding pressure profile regulated via polygon with 4 base points
- Programmable delay times for all movements
- Screw circumferential speed display
- Positive and negative programmable back pressure
- Dosage time display with programmable dosage time monitoring
- Dosage possible before or after nozzle retraction
- Material decompression with programmable decompression speed
- Dosage with electro-mechanical servo drive, energy-saving
- Nozzle contact force relief for continuous nozzle contact
- Open nozzle with screw-in tip
- Needle type shut off nozzle, spring force actuated
- Needle type shut off nozzle, hydraulically actuated
- Zone-dependent monitoring of heating circuits for continuity, short circuit and defective sensors
- Temperature monitoring with release tolerance range and zone-dependent monitoring tolerance
- Automatic temperature sink can be selected in case of error or after automatic switch-off
- 8 litre corrosion proof stainless steel material hopper movable to a blocking and emptying position
- Granulate feed zone temperature programmable and regulated with monitoring

Extended functions

- Extended monitoring of the mechanical sequence of mould and machine for complex applications
- Extended drive movements: increase in number of movement stages, intermediate stop functions and extended locking force program
- Production control with nominal temperature value control, programmable alarm cycles, programmable switch-on / switch-off sequences as well as time-controlled automatic switch-on/off in second programming level for follow-up batch

Regulated parameters

- Control cabinet temperature
- Hydraulic oil temperature
- Plasticising cylinder temperature (adaptive)
- Screw rotation speed
- Injection flow or injection speed
- Holding pressure
- Movements and force of mould, nozzle and ejector
- Ramp function for movement of mould, ejector and nozzle movement
- Back pressure
- Electrical mould heating circuits (adaptive)
- Mould cooling circuits
- Internal cavity pressure or screw chamber pressure (external sensor)
- Screw position
- Granulate feed zone temperature

- Basic machine
- Options

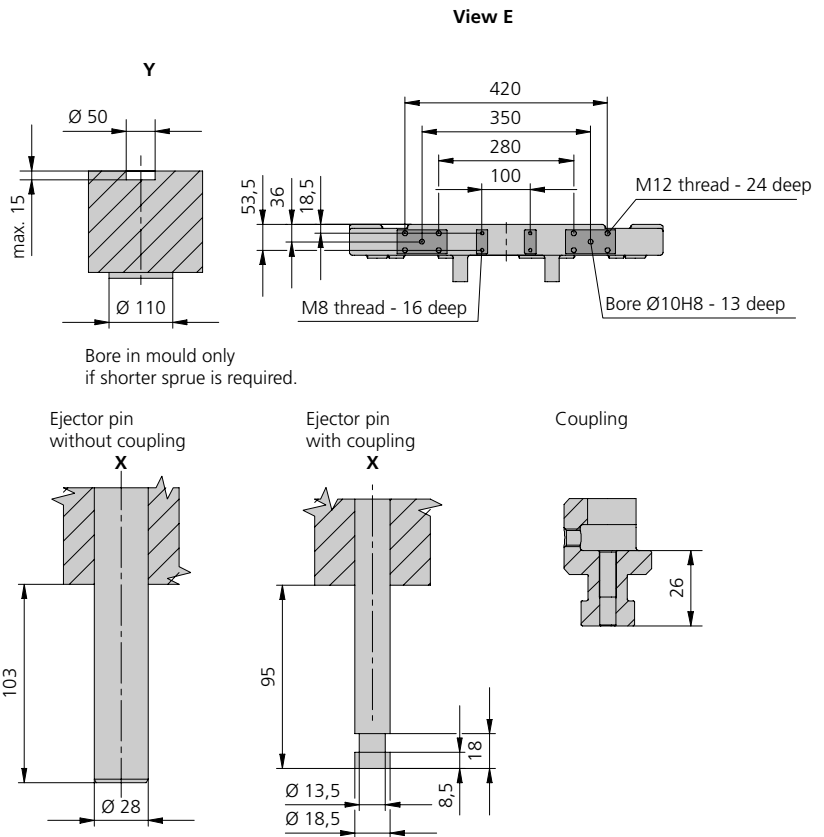
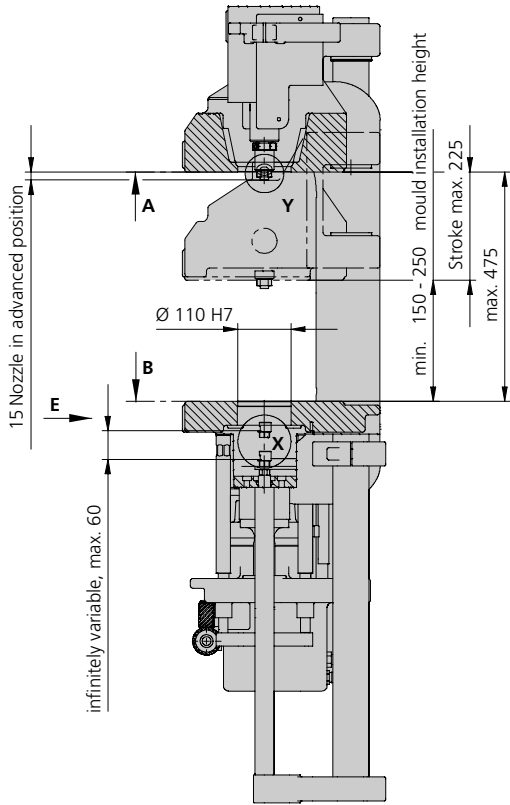

Mould installation dimensions for parting line injection

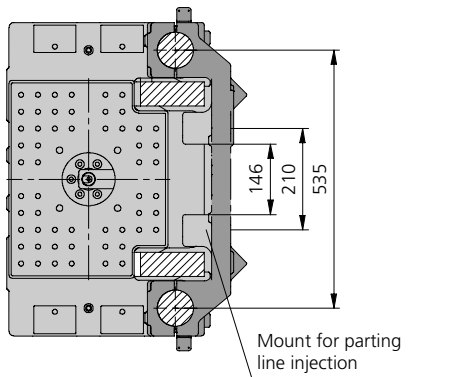
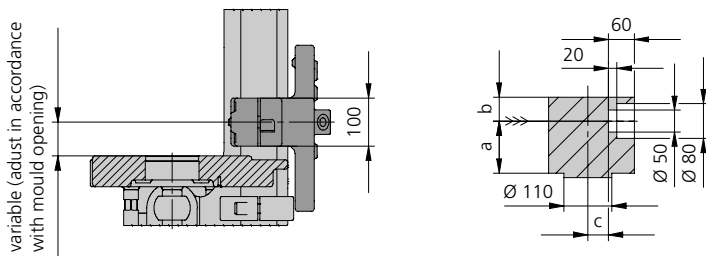

Injection positions	with hydraulic nozzle
a min.	80
a max.	150
b min.	50
c min.	71

Bore in mould only if shorter sprue is required. Dimensions in conjunction with hydraulic nozzle upon request

Movable mould platen
(top)

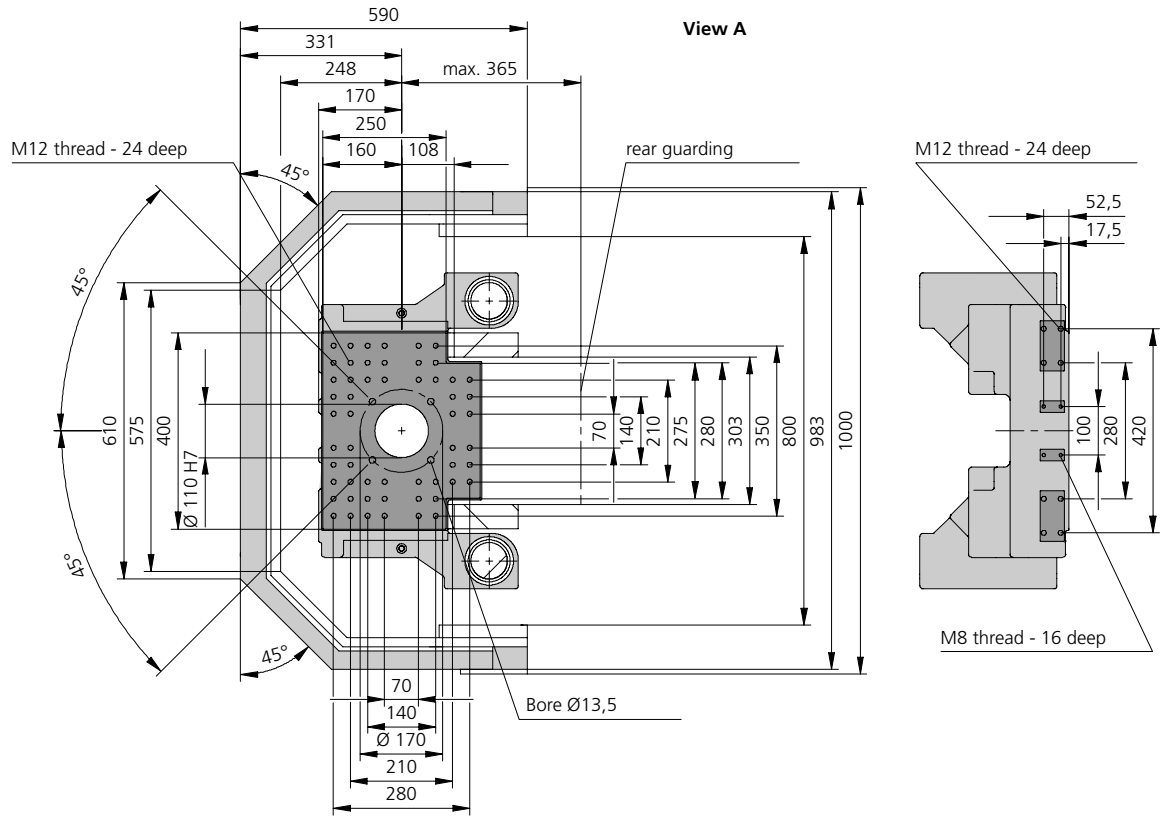

(bottom)

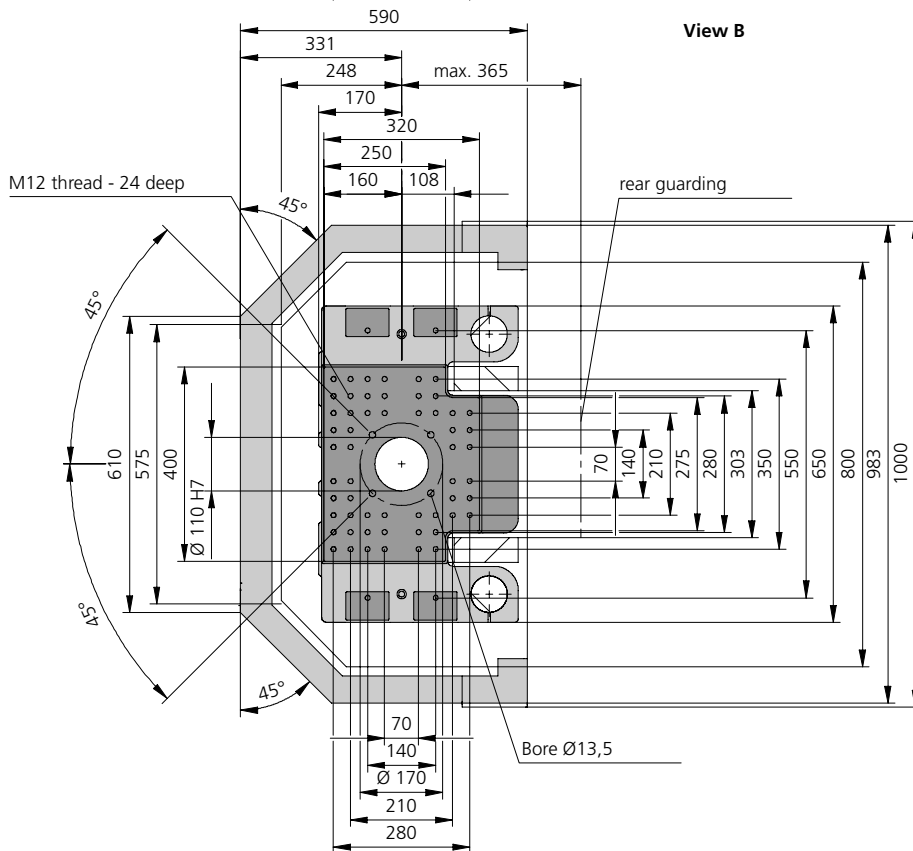

Maximum theoretical shot weights for the most important injection moulding materials (in grams)

Injection units according to EUROMAP		70			100		
Screw diameter	mm	18	22	25	20	25	30
Polystyrene	PS	21	31	40	29	45	65
Styrene heteropolymerizates	SB	20	31	39	28	44	63
	SAN, ABS ¹⁾	20	30	39	27	43	62
Cellulose acetate	CA ¹⁾	24	35	45	32	50	73
Celluloseacetobutyrate	CAB ¹⁾	22	33	42	30	47	68
Polymethyl methacrylate	PMMA	22	32	42	30	46	67
Polyphenylene ether, mod.	PPE	19	29	37	27	42	60
Polycarbonate	PC	22	33	42	30	47	68
Polysulphone	PSU	23	34	44	31	49	70
Polyamides	PA 6.6, PA 6 ¹⁾	21	31	40	28	44	64
	PA 6.10, PA 11 ¹⁾	19	29	37	26	41	60
Polyoximethylene (Polyacetal)	POM	26	39	50	35	55	80
Polyethylene terephthalate	PET	25	37	48	34	53	77
Polyethylene	PE-LD	16	24	30	22	34	49
	PE-HD	16	24	31	22	35	50
Polypropylene	PP	17	25	32	23	36	51
Fluoropolymerides	FEP, PFA, PCTFE ¹⁾	33	50	65	46	72	103
	ETFE	29	44	57	40	63	91
Polyvinyl chloride	PVC-U	25	38	49	35	54	78
	PVC-P ¹⁾	23	35	45	32	50	72

1) average value

ARBURG GmbH + Co KG

Postfach 11 09 · 72286 Lossburg · Tel.: +49(0)7446 33-0 · Fax: +49(0)7446 33-3365 · www.arburg.com · e-mail: contact@arburg.com

With locations in | Europe: Germany, Belgium, Denmark, France, United Kingdom, Italy, Netherlands, Austria, Poland, Switzerland, Slovakia,Spain, Czech Republic, Turkey, Hungary | **Asia:** People's Republic of China, Indonesia, Malaysia, Singapore, Thailand | **America:** Brazil, Mexico, USAFor more information, please go to **www.arburg.com**.

© 2009 ARBURG GmbH + Co KG

The brochure is protected by copyright. Any utilisation, which is not expressly permitted under copyright legislation, requires the previous approval of ARBURG.

All data and technical information have been compiled with great care. However, we are unable to guarantee its correctness. Individual illustrations and information may deviate from the actual delivery condition of the machine. The relevant valid operating instructions are applicable for the installation and operation of the machine.

**ARBURG GmbH + Co KG Quality:**

DIN EN ISO 9001 + 14001 certified