

ALLROUNDER 720 A

Clamp-Design

Distance between tie bars: 720 x 720 mm



Clamping force: 3200 kN

Injection unit (acc. to EUROMAP): 800, 1300, 2100

ARBURG

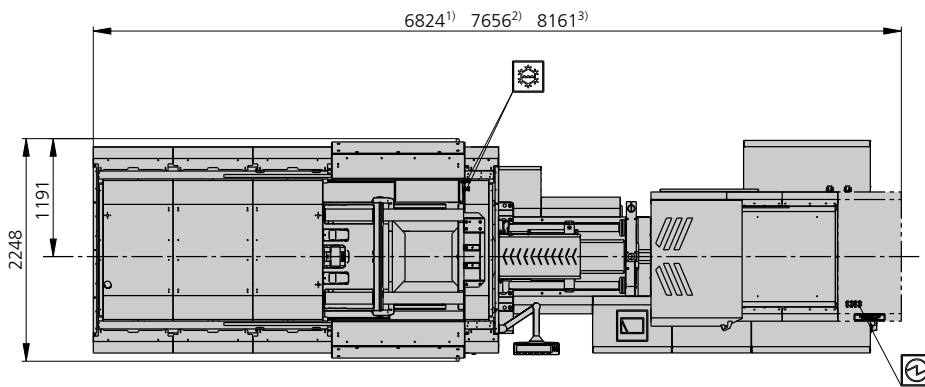
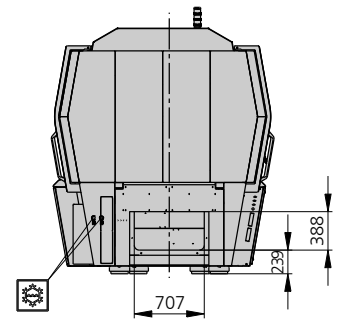
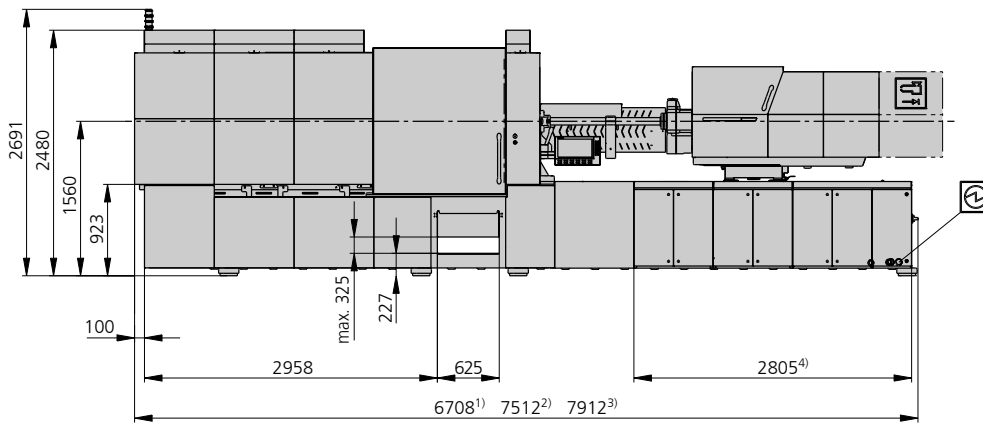
MACHINE DIMENSIONS | 720 A



-  Electrical connection
-  Cooling water connection

- 1) Injection unit 800
- 2) Injection unit 1300
- 3) Injection unit 2100
- 4) Depending on the power and size of the injection unit

TECHNICAL DATA | 720 A

Clamping unit			720 A
with clamping force	max. kN		3200
Opening force stroke	max. kN mm		--- 600
Mould height, fixed variable	min.-max. mm		--- 300-800
Platen daylight fixed variable	max. mm		--- 900-1400
Distance between tie bars (w x h)	mm		720 x 720
Mould mounting platens (w x h)	max. mm		1040 x 1040
Weight of movable mould half	max. kg		2900
Ejector force stroke	max. kN mm		86 250
Dry cycle time EUROMAP	Comfort	min. s - mm	2,3 - 504
	Ultimate	min. s - mm	1,5 - 504

Injection unit			800			1300			2100		
with screw diameter	mm		45	50	55	55	60	70	60	70	80
Effective screw length	L/D		22	20	18	22	20	17	23	20	17,5
Screw stroke	max. mm		200			240			280		
Calculated stroke volume	max. cm ³		318	392	474	570	678	923	792	1078	1407
Shot weight	max. g PS		291	359	434	521	620	844	723	984	1286
Material throughput	max. kg/h PS		46	53	59	86	96	115	125	145	175
	max. kg/h PA6.6		23	27	30	43	48	58	62	74	88
Injection pressure	max. bar		2470	2000	1650	2380	2000	1470	2500	2000	1530
Holding pressure time	max. s - bar		300-1980	300-1600	300-1320	300-1900	300-1600	300-1170	300-2180	300-1600	300-1220
Injection flow ²	Comfort [+]	max. cm ³ /s	175 [239]	216 [295]	261 [356]	261 [356]	311 [424]	423 [577]	339 [452]	462 [616]	603 [804]
	Ultimate [+]	max. cm ³ /s	318 [477]	394 [591]	476 [714]	476	566	772	707 [919]	962 [1251]	1257 [1634]
Injection speed ⁵	Comfort [+]	max. mm/s	150 [200]			110 [150]			120 [160]		
	Ultimate [+]	max. mm/s	240 [300]			200			250 [325]		
Screw circumferential speed	max. m/min		54	60	66	55	60	70	51	60	69
Screw torque	max. Nm		900	1000	1100	1510	1640	1920	2140	2500	2850
Nozzle contact force retraction stroke	max. kN mm		70 400			90 500			110 600		
Heating capacity zones	kW		19,9 8			22,9 8			31,2 8		
Feed hopper	l		---			---			---		

Drive and connection			Comfort			Ultimate		
with injection unit			800	1300	2100	800	1300	2100
Net weight of machine	kg		15950	17350	19050	16450	17850	19550
Sound press. level Insecurity ⁴	dB(A)		60 3			60 3		
Electrical connection ³	kW		52	68	93	58	74	98
	Total	A	116	145	---	113	138	---
	Machine	A	80	125	160	100	125	160
	Heating	A	35	40	50	35	40	50
Cooling water connection	max. °C		30			30		
	min. Δp bar		1,5 DN 25			1,5 DN 25		

Machine type
with EUROMAP size designation ¹
720 A 3200-800 | 1300 | 2100

Upon request: other machine types and mould installation heights, screws, drive powers etc.

All specifications relate to the basic machine version. Deviations are possible depending on variants, process settings and material type. Depending on the drive, certain combinations, e.g. max. injection pressure and max. injection flow may be mutually exclusive.

- 1) Clamping force (kN) - size of injection unit = max. stroke volume (cm³) x max. injection pressure (kbar)
 - 2) Specification of maximum injection flow at maximum injection pressure.
 - 3) Specifications relate to 400 V/50 Hz.
 - 4) Emission sound pressure level at the workplace. Detailed information in the operating instructions.
 - 5) Forward speed of plasticising screw at 1000 bar injection pressure.
- [] Specifications apply to alternative equipment.

MOULD INSTALLATION DIMENSIONS | 720 A

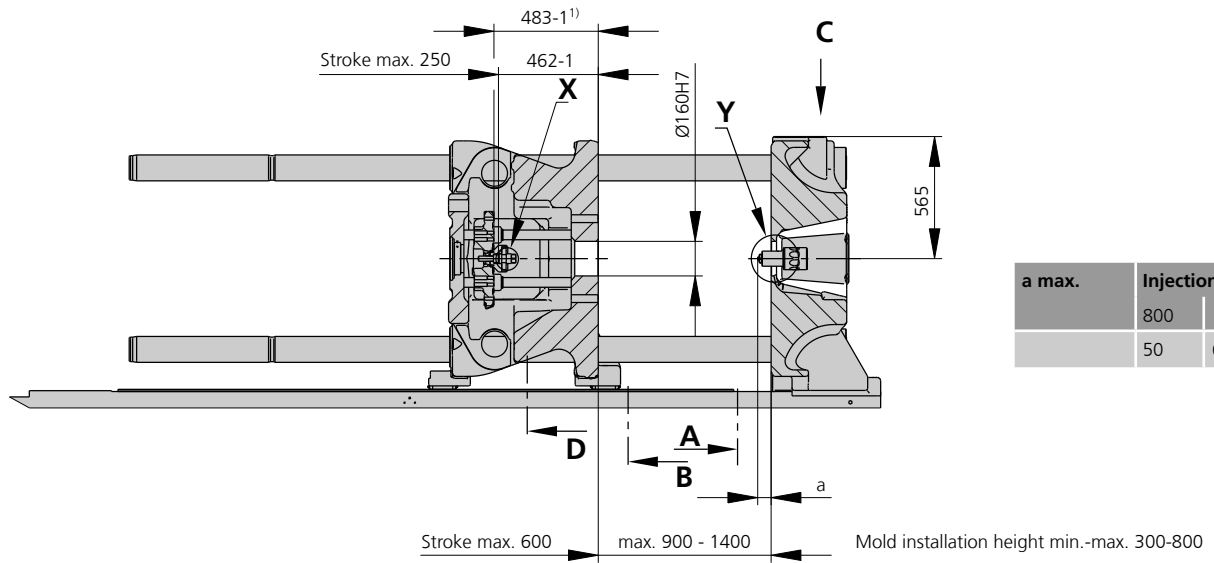

a max.	Injection unit	
		800
	50	60

Ejector bolt | X

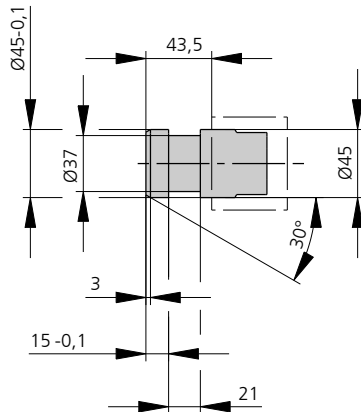

Bore in mould (if required) | Y

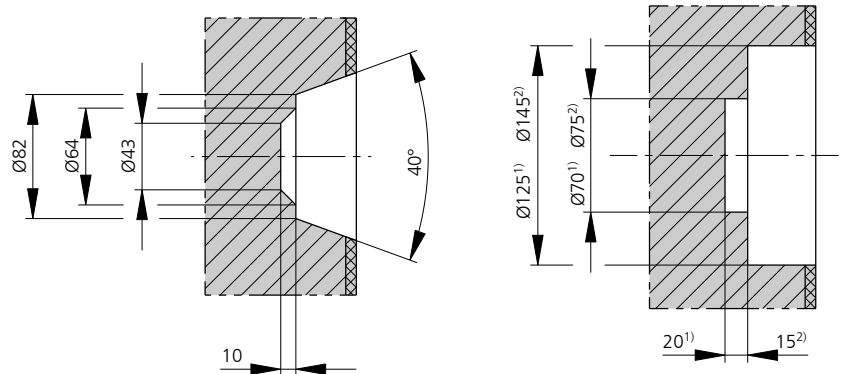

Injection unit 800¹⁾ and 1300²⁾ in thermoset version - Injection unit 2100 available on request

Closing force for spring moulds / during injection compression moulding*

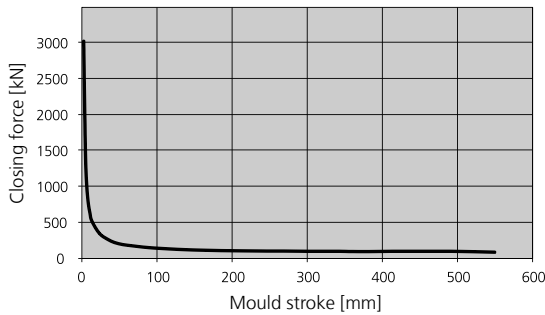

* automatic locking force adjustment up to 25 kN

Ejector plate | D

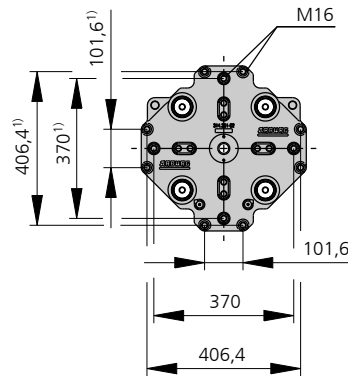

Robotic system mounting | C

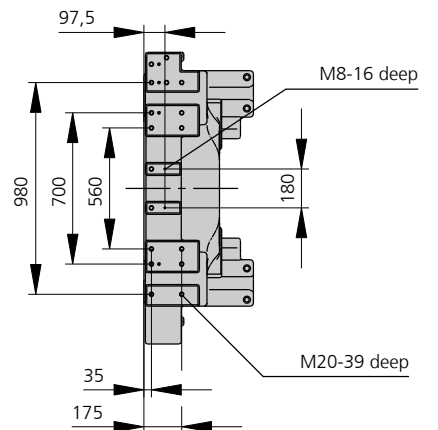

1) Ejector plate position
Optional: Reinforced mounting platen (see variant 3)

MOULD INSTALLATION DIMENSIONS | 720 A

Fixed mould mounting platen | A

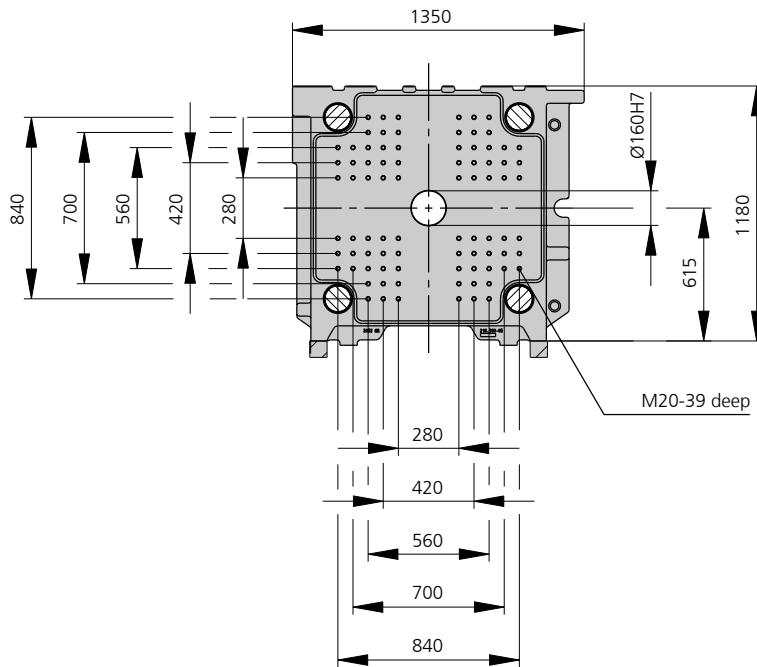

Moving mould mounting platen | B

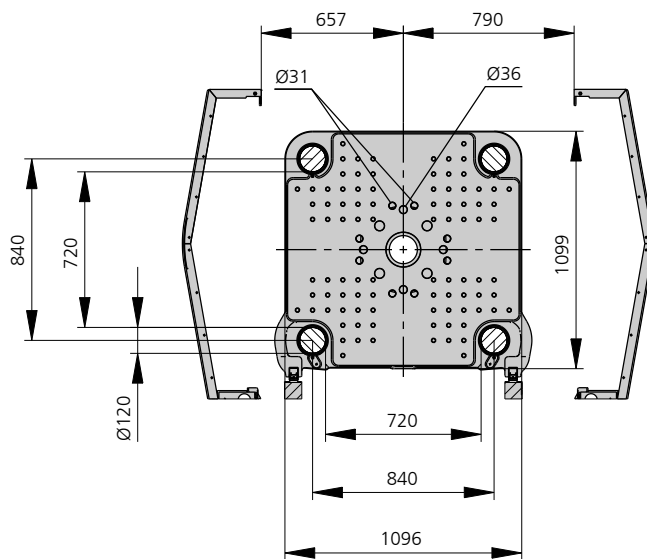

SHOT WEIGHTS | 720 A

Theoretical shot weights for the most important injection moulding materials

Injection units according to EUROMAP		800			1300			2100		
Screw diameter	mm	45	50	55	55	60	70	60	70	80
Polystyrene	max. g PS	291	359	434	521	620	844	723	984	1286
Styrene heteropolymerizates	max. g SB	284	350	424	509	606	824	707	962	1256
	max. g SAN, ABS ¹⁾	278	344	416	499	594	808	693	943	1231
Cellulose acetate	max. g CA ¹⁾	327	404	488	586	698	949	814	1108	1447
Celluloseacetobutyrate	max. g CAB ¹⁾	304	375	454	545	649	883	757	1030	1346
Polymethyl methacrylate	max. g PMMA	300	371	449	538	641	872	747	1017	1329
Polyphenylene ether, mod.	max. g PPE	270	333	403	484	575	783	671	914	1194
Polycarbonate	max. g PC	305	377	456	547	651	887	760	1034	1351
Polysulphone	max. g PSU	316	390	471	566	673	916	785	1069	1396
Polyamides	max. g PA 6.6 PA 6 ¹⁾	289	357	431	517	616	838	719	978	1278
	max. g PA 6.10 PA 11 ¹⁾	270	333	403	473	575	783	671	914	1194
Polyoximethylene (Polyacetal)	max. g POM	359	443	536	643	765	1042	893	1215	1588
Polyethylene terephthalate	max. g PET	346	427	517	620	738	1005	861	1172	1531
Polyethylene	max. g PE-LD	219	271	328	393	468	637	546	744	971
	max. g PE-HD	227	280	339	406	483	658	564	768	1003
Polypropylene	max. g PP	232	286	346	415	494	672	576	784	1025
Fluoropolymerides	max. g FEP, PFA, PCTFE ¹⁾	465	574	695	834	992	1350	1157	1575	2058
	max. g ETFE	408	504	609	731	870	1185	1015	1382	1805
Polyvinyl chloride	max. g PVC-U	351	434	525	629	749	1020	874	1190	1554
	max. g PVC-P ¹⁾	324	401	485	582	692	942	808	1099	1436

1) average value

ARBURG GmbH + Co KG
 Arthur-Hehl-Strasse
 72290 Lossburg
 Tel.: +49 7446 33-0
 www.arburg.com
 contact@arburg.com